

Feasibility Report

Version 1.1



Project Name:	MetroWest Phase 2 (Henbury & Yate Services)
OP Reference:	139797
Sponsor:	Andrew Holley
Project Manager:	Rachel Leighfield Finch

Signature		
Prepared By: 	Name: Rachel Leighfield Finch	Name: Laura Hemsley
	Job Title: Project Development Manager	Job Title: Project Manager, URS
	Date: 29/06/2015	Date: 09/02/2015
Accepted By: 	Name: Andrew Holley	Name: Alistair Rice
	Job Title: Senior Development Manager	Job Title: Project Manager, West of England Partnership
	Date:	Date:

Ref:	139797
Version:	1.1
Date:	June 2015

This page left deliberately blank

Ref:	139797
Version:	1.1
Date:	June 2015

Contents

1. Executive Summary	1
2. Introduction & Route Histories	9
2.1 The Filton Bank Route	10
2.2 Ashley Down (formally known as Ashley Hill)	11
2.3 Horfield (Constable Road)	12
2.4 North Filton	12
2.5 Henbury	13
2.6 Yate	14
3. Business Objective	16
3.1 Problem Identified	16
3.2 MetroWest Concept	17
3.3 MetroWest Phase 2	18
3.4 MetroWest Phase 2 Project Objectives	18
4. Business Case	19
4.1 Business Strategy	19
4.2 MetroWest Governance	19
4.3 Business Case Approach	20
4.4 Business Case Approach	20
4.5 Business Case Timescales	20
5. Project Scope	21
6. Deliverables	22
7. Options Considered	23
7.1 Services to Henbury	23
7.2 Provision for the Turnback of Services at Yate	24
8. Engineering Options – General Considerations	25
8.1 General	25
8.2 Land Ownership	25
8.3 Statutory Powers	25
8.4 Rights of Way	25
9. Engineering Options	26
9.1 Ashley Down	26
9.2 Constable Road	26
9.3 North Filton	26

Ref:	139797
Version:	1.1
Date:	June 2015

9.4	Henbury Option 1 (Eastern 'New' Station Location)	35
9.5	Henbury (Option 2 Western Former Station Location)	41
9.6	Yate	54
9.7	Hallen Marsh Junction (including Holesmouth Junction)	58
10.	Constructability and Access Strategy	63
10.1	Constructability	63
10.2	Access Strategy	65
11.	Cost Estimate	68
12.	Project Risks and Assumptions	69
13.	High level business case appraisal against whole life costings	70
14.	Project Schedule	71
15.	Capacity/Route Runner Modelling	72
16.	Interface with other projects	73
17.	Impact on existing customers, operators and maintenance practice	74
18.	Consents Strategy	75
19.	Environmental Appraisal	76
20.	Common Safety Method for Risk Evaluation Assessment (CSM)	77
21.	Client Contracting Strategy	78
22.	Concept Design Deliverables	81
23.	Conclusion and Recommendations	82

Ref:	139797
Version:	1.1
Date:	June 2015

Appendices

- A** Contract Requirements
- B** CH2MHILL Report – Bristol New Stations – High Level Assessment Study
- C** URS Review of CH2MHILL report
- D** Cost Estimate
- E** Risk Register
- F** Capability Modelling
- G** Environmental Appraisal
- H** Network Rail Signalling Feasibility Report (SDG)
- I** Photograph gallery
- J** Concept Design Drawings
- K** DRN Comments

Ref:	139797
Version:	1.1
Date:	June 2015

Issue Record

Issue No	Brief History Of Amendment	Date of Issue
0.01	First Draft	04/12/2014
0.02	Second Draft	13/01/2015
0.03	Third Draft	09/02/2015
0.04	Fourth Draft	01/05/2015
0.05	Fifth Draft	29/05/2015
1.0	Final Issue	11/06/2015
1.1	Typing / spelling errors corrected	29/06/2015

Distribution List

Name	Organisation	Issue No.
Rachel Leighfield Finch	Network Rail Project Development Manager	0.01
Alistair Rice	South Gloucestershire Council	0.01
Rachel Leighfield Finch	Network Rail Project Development Manager	0.02
Alistair Rice	South Gloucestershire Council	0.02
Rachel Leighfield Finch	Network Rail Project Development Manager	0.03
Alistair Rice	South Gloucestershire Council	0.03
Alistair Rice Helen Spackman	South Gloucestershire Council CH2M Hill	0.04
Claire Mahoney	Network Rail Principal Strategic Planner	0.05
Alistair Rice Helen Spackman	South Gloucestershire Council CH2M Hill	1.0
Alistair Rice Helen Spackman Route Asset Managers	South Gloucestershire Council CH2M Hill Network Rail	1.1

Ref:	139797
Version:	1.1
Date:	June 2015

Abbreviations

ADSL - Asymmetric Digital Subscriber Line

AFR – Avonmouth and Filton Railway (Henbury Line)

AMB – Avonmouth Branch (Severn Beach to Avonmouth)

BASRE - Bristol Area Signalling Relock & Recontrol Project

BRB - British Railways Board

BRT - Bus Rapid Transport

BSW – Bristol and South Wales Union Line

CCTV - Closed Circuit Television

CIS - Customer Information Systems

CNX – Clifton and Avonmouth Line

CPNN – Cribbs Patchway New Neighbourhood

CWR - Continuous Welded Rail

DDA - Disability Discrimination Act

DfT - Department for Transport

DMU – Diesel Multiple Unit

DNO - Distribution Network Operator

DOO - Driver Only Operated

EIA - Environmental Impact Assessment

FWC – Filton West Chord

GPDO - General Permitted Development Order

GRIP - Guide to Rail Investment Projects

GSM - Global Systems Mobile

GSM-R - Global Systems Mobile (Rail)

LED - Light Emitting Diode

NCN – National Cycle Network

NR - Network Rail

OLE - Overhead Line Equipment

ORR - Office of Rail & Road

OSS – Overspeed Sensor

PA - Public Address

PADS - Parts and Drawing Systems

PHP - Passenger Help Points

PID - Project Initiation Document

REB - Relocatable Equipment Building

Ref:	139797
Version:	1.1
Date:	June 2015

RRAP – Road Rail Access Points
QCRA - Qualitative Cost Risk Analysis
ROGS - Railway and Other Guided Transport Systems
RSSB – Railway Safety and Standards Board
RUS - Route Utilisation Strategy
SISS - Station Information & Surveillance Systems
SSSI - Site for Special Scientific Interest
SUDS - Sustainable Urban Drainage System
TBI - Trackbed Investigation
TOC - Train Operating Company
TPWS – Train Protection and Warning System
TSS – Train Stop Sensor
TVSC - Thames Valley Signalling Control
WoE - West of England

Ref:	139797
Version:	1.1
Date:	June 2015

1. Executive Summary

This Report has been produced at the request of the Network Rail Senior Sponsor, on behalf of South Gloucestershire Council and the West of England Partnership of Councils (WoEP). The West of England Partnership of Councils comprise of South Gloucestershire, Bristol City, North Somerset, Bath & North East Somerset Councils who are jointly promoting MetroWest (MW). This GRIP 2 study is being delivered through a Development Services Agreement (DSA) with South Gloucestershire Council, the Lead Authority for Phase 2.

A GRIP 2 study for MetroWest Phase 1 was completed in July 2014. The WoEP requested Network Rail to undertake a GRIP 2 study to develop the options for MetroWest Phase 2, building on the feasibility work already undertaken for Phase 1.

- Phase 1 includes re-opening of the Portishead Line for passenger services and improving service frequencies on the Severn Beach and Bath Spa Lines.
- Phase 2 is to improve the frequency of services at Yate and to introduce passenger services on the Henbury Line with new station(s) on the Filton Bank.

The West of England local authorities are promoting MetroWest to provide operational rail services which include:

- Phase 1 – up to half hourly train services for the Severn Beach line, local stations between Bristol Temple Meads, Bath Spa and to Portishead (on the re-opened line). Service operation is proposed for 2019.
- Phase 2 – half hourly train services to Yate and hourly services on a re-opened Henbury Line (capacity for two new stations) with possible additional station(s) on Filton Bank (between Filton Abbey Wood and Stapleton Road stations). Service operation is proposed for 2021.

The Phase 2 findings in this report are based on:

- an extension of the Network Rail Capability Analysis MetroWest Phase 1 Report dated July 2014 to identify a timetable specification which delivers the requirements for MetroWest Phase 2. The results of this work are summarised in the Group Strategy-Capability Analysis MetroWest Phase 2 Report in Appendix F. It should be noted that the timetable modelling has paid due cognisance to maintaining the existing freight path agreements.
- the following reports commissioned by Bristol City Council and South Gloucestershire Council as identified below:
 - CH2M Hill Bristol North Fringe Stations Report - March 2014 (published on the TravelWest website)
 - CH2M Hill Bristol New Stations High Level Assessment Study – Locations on Filton Bank GRIP 1 Report v5 - May 2014 (see Appendix B)

Ref:	139797
Version:	1.1
Date:	June 2015

Network Rail has undertaken a business case economic analysis and appraisal to support a wider socio-economic appraisal (value for money assessment and Benefit Cost Ratio) for the GRIP 2 Phase 2 scheme. The appraisal for each option was carried out in accordance with the Department for Transport's appraisal guidance. The report has been provided to South Gloucestershire Council.

This feasibility study is based on the following infrastructure assumptions:

- BASRE - Bristol Area Signalling Relock & Recontrol project is completed
- Great Western Electrification of the main lines is delivered
- Filton Bank 4 tracking enhancement is delivered
- Enhanced capability of Bristol East Junction
- Bristol Temple Meads IEP Platform 1 extension completed

MetroWest train services propose to operate with Class 150/165/166 trains in either 2 or 3 car formations.

Infrastructure requirements considered or reviewed by this GRIP 2 feasibility study are summarised as:

1. the reintroduction of passenger services to Henbury as either a Loop or a Spur service including the provision of two stations, one at Henbury and the other at North Filton
2. provision a new station(s) on the Filton Bank at Ashley Down and/or Constable Road
3. provision of turnback facilities at Yate

The study builds on the two MetroWest Phase 1 service pattern options (5b & 6b) identified as part of the Capability Analysis work undertaken for Phase 1 which are summarised in the table below:

Option	5B	6B
Services	Severn Beach – Bath Spa	Bath Spa - Portishead
	Avonmouth – Portishead	Avonmouth - Portishead
	Portishead – Bristol Temple Meads	Severn Beach – Bristol Temple Meads

The Phase 2 Capability Analysis (Appendix F) confirms that capacity exists to be able to deliver the proposed Phase 2 service specification for a loop or a spur service should the proposed infrastructure interventions be delivered. However, the timetable modelling does highlight that linking the loop service to the proposed Phase 1 Portishead services at Bristol Temple Meads to then connect to Severn Beach Line

Ref:	139797
Version:	1.1
Date:	June 2015

services and create the proposed 'loop service' would import unacceptable performance risk to the industry. An alternative scenario for a standalone loop service was explored however this option would result in train units idling at Bristol Temple Meads (or an alternative stabling facility would need to be created) for an extended period of time utilising valuable platform capacity and impacting on train performance in the station area. It is also unlikely to be supported by a value for money business case due to the inefficient use of resources. The extended dwell time would also impact and spread performance delay to the wider Bristol and Western Route area.

1. Henbury

This report explores the options to enable passenger services to operate to Henbury via a loop line or a spur:

- Loop line – a bi-directional circular service via Bristol Temple Meads, Avonmouth, Henbury, the Filton Bank and Bristol Temple Meads
- Spur line - from Bristol Temple Meads via the Filton Bank terminating at Henbury

The report examines locations for stations at Ashley Down, Constable Road, North Filton and two alternative locations for a new station at Henbury:

- A greenfield site to the east of the A4018 Wyck Beck Road, referred to as the Eastern Location
- The site of the historic Henbury station utilising the location of the existing platforms. Other station infrastructure, access and car parking would be from land to the north of and adjacent to the site. This station location is referred to as the Western Location

The station layouts at Henbury only are different for the loop and spur service options as explained in paragraphs 1.1 and 1.2 below.

There are no proposals to increase the current linespeed, which is considered adequate for the proposals under consideration.

1.1 Henbury Loop Service Option

A loop service will require the doubling of Hallen Marsh Junction and additional crossovers on the Henbury Line (AFR) to maintain capacity and to enable the regulation of freight traffic. To alter Hallen Marsh Junction layout to enable both passenger and freight traffic to operate will require significant associated trackwork and extensive signalling alterations. The Capability Modelling Report also highlights that the loop option imports a high level of performance risk and requires significant platform capacity at Bristol Temple Meads which is unlikely to be supported by the rail industry.

Ref:	139797
Version:	1.1
Date:	June 2015

To support a loop service at the new Eastern location (option 1B) the site will require two new single faced platforms adjacent to the Up and Down Branch lines. The new platforms would be on a curve and on a gradient of approximately 1:120 which is steeper than the maximum of 1:500 set out in Railway Group Standards. Approval to deviate from the Standard will need to be sought from Network Rail Head of Track Engineering and ultimately the Railway Safety and Standards Board (RSSB).

A station at the Western location (option 2B) would have platforms at the site of the historic Henbury Station although the platforms will need to be rebuilt. As with the new station location the platforms are on a curve; the gradient is approximately 1:264. Although the Western location is an historic station site if this option is chosen a derogation to deviate from Railway Group Standards will still need to be sought. The Signalling Feasibility Report (Appendix H) concludes that for Henbury loop service options there are no alternations required to the existing signalling arrangements for either option 1B or 2B station sites.

As both station site options are on gradients in excess of the minimum Standard requirement an assessment of the operational risk was undertaken by Network Rail on 19th February 2015. The meeting was attended by representatives from Passenger and Freight train operating companies.

The operations risk meeting agreed that the risks associated with the construction of the new station would be as low as reasonably practicable subject to:

- Noise issues to be considered through the planning approvals process and suitable and sufficient mitigations to be implemented
- Appropriate operational instructions to be issued to cover the operation of passenger services with engines isolated / running on reduced power to cover the risk of a train being unable to start away from a station stop
- if the pre-existing site (option 2B) was chosen for the new station signal SA24 should be fitted with TPWS, Train Stop Sensor (TSS) & Overspeed Sensor (OSS).

It should be noted that the meeting assessed the operational risk against the relevant Group Standard for train operations only. This assessment process did not look at the wider non train movement factors of performance or network capacity impact of a new station. The project will need to assess the wider component impacts in the next GRIP stage.

The loop option service will see an increase in the number of trains over St. Andrews Road Level Crossing. The study looked at whether there were any track or signalling interventions which could be made to reduce the level crossing barrier down time at the crossing. From a track perspective a solution is not readily available to reduce the extended road closure time. Signalling Design Group reviewed the level crossing controls and in summary there are no signalling control alternations available to reduce the level crossing barrier down time. Refer to the SDG Report in Appendix H.

Ref:	139797
Version:	1.1
Date:	June 2015

1.2 Henbury Spur Service Option

A new crossover and a new turnout leading to a bay platform line will be required to operate a spur service at either the Eastern (option 1A) or Western (option 2A) location. Train services would terminate off the running lines into the bay platform, which would be on the north-side of the running lines. The bay line and platform would be constructed to a level gradient and on a straight horizontal alignment to meet the Standard for terminating services. Sufficient interval between the Up Branch line and the bay line would be retained to enable the construction of a single faced platform adjacent to the Up Branch line should a future loop service be required.

A new buffer stop, axle counter alterations, relocation of signals and signalling data changes will be required for both Eastern & Western spur option station sites.

1.3 North Filton Station

This Station is located at the site of the former North Filton Platform adjacent to Filton Airfield and the A38. Both the loop and spur options require two single faced platforms one either side of the Up and Down Branch lines. Retention of the existing platform walls is subject to survey. The platforms are on a gradient of approximately 1:210 and although they are historic a derogation to deviate from Railway Group Standards will need to be sought. Alterations to the signalling will be necessary irrespective of whether a loop or spur service option is selected; refer to the Signalling Feasibility Report (Appendix H).

The operational risk of this site was assessed by attendees at the Network Rail meeting of 19th February 2015. The meeting agreed that the risks associated with the construction of a station at this site would be as low as reasonably practicable subject to:

- Noise issues to be considered through the planning approvals process and suitable and sufficient mitigations to be implemented
- Appropriate operational instructions to be issued to cover the operation of passenger services with engines isolated / running on reduced power to cover the risk of a train being unable to start away from a station stop.
- A review of the Operational Instructions and Timetable regarding loaded freight services from Avonmouth receiving clear run conditions from Filton West to Patchway or Stoke Gifford so as not to delay following services

Additional Station(s) on Filton Bank

The Dr Days to Filton Abbey wood Capacity Improvement project is to reinstate the former arrangement of main lines and relief lines on the Filton Bank with the main lines to the East and the relief lines to the West. This study has assessed the operational aspect of providing two additional stations at Ashley Down and Constable Road. Any new Stations on Filton Bank would be constructed on the relief lines only and will only be served by local, stopping services. However, any new station would not open for

Ref:	139797
Version:	1.1
Date:	June 2015

passenger services until the Filton 4-tracking project and electrification of the line has been completed.

Filton Bank is on a 1:75 gradient throughout rising from Narrowways Junction to Filton for 1m70ch. Both the Ashley Down and Constable Road sites were assessed as part of the operational risk meeting of 19th February 2015, see outcome for each site in the paragraphs below. Note the operation assessment did not look at the wider non train movement factors of performance or network capacity impact of a new station(s). Both stations require a derogation from the Rail Safety and Standards Board to deviate from Railway Group Standards to build and operate a station(s) on a 1:75 gradient. Ashley Down, being a former station location is more likely to receive a derogation than the proposed new station location at Constable Road.

Ashley Down and Constable Road are within close proximity of each other and relatively close to Filton Abbey Wood Station. The WoEP will need to determine as part of the business case whether the area can support the demand for two further stations within half a mile of each other and review the impact on abstraction and journey times. In addition further work will need to be undertaken to assess the wider impacts on passenger and freight train performance and network capacity of having any new station(s) on the Filton Bank. The support and agreement of the train operator will also be required in order to ensure provision of services to call at any new station.

2.1 Ashley Down

Ashley Down is in the vicinity of the former Ashley Hill Station. Station platforms for Ashley Down Station would be located on the relief lines adjacent to Station Road. Network Rail was remitted to review the CH2M report in Appendix B, to update the cost estimates and undertake an operational risk assessment.

The Signalling Feasibility Report (Appendix H) concludes that there are no alternations required to the existing signalling arrangements.

The operational risk meeting of 19th February 2015 agreed that the risks associated with the construction of a station at this site on a 1:75 gradient would be as low as reasonably practicable subject to:

- Noise issues to be considered through the planning approvals process and suitable and sufficient mitigations to be implemented
- Appropriate operational instructions to be issued to cover the operation of passenger services with engines isolated / running on reduced power to cover the risk of a train being unable to start away from a station stop
- Signal BL1589 on the Down Relief line protecting Ashley Down to be fitted with TPWS, TSS & OSS.

Ref:	139797
Version:	1.1
Date:	June 2015

2.2 Constable Road

This is a new station site in the vicinity of Constable Road with vehicle access through a small industrial estate off of Romney Avenue; refer to CH2M Hill Report in Appendix B. Network Rail was remitted to review the CH2M report in Appendix B, to update the cost estimates and undertake an operational risk assessment.

The Signalling Feasibility Report (Appendix H) notes that Constable Road Station approach signals have TPWS and that some existing signals will need to be relocated. The operations risk meeting agreed that other than the noise issue and operational instructions for trains starting away no further reasonably practicable mitigations were proposed as TPWS is fitted to all signals.

2. Yate

The GRIP 2 study looked at improving the frequency of services to Yate as an extension of the existing Weston-super-Mare – Bristol Parkway service rather than a new service to create two trains per hour. The Capability Analysis Report (Appendix F) indicates there would be a risk to performance for trains with short turnaround time on the main lines and trains with a long turnaround would need to be stabled off the running lines. To this end a new turnback siding is proposed on the Down side north of Yate Station, located within the existing railway boundary. The area identified would require vegetation clearance. A new buffer stop, drivers walkway, walkway lighting, axle counter alterations, new signalling, signalling data changes will be required.

Passengers would alight from the train on arrival at Platform 2, the train would then move to the turnback siding. The driver changes ends and awaits a timetabled move to proceed from the turnback siding to Platform 2 for passengers to board for Bristol Parkway – Weston-super-Mare.

There is the capacity identified within the current timetable modelling for train services to extend beyond Yate to Gloucester which would avoid the requirement to provide a turnback facility at Yate however additional operating costs would be incurred. It is recommended that discussions continue with Gloucestershire County Council. Further timetable / performance modelling work will be required in GRIP 3.

Cost:

A GRIP2 cost estimate has been prepared by Network Rail which incorporates an update of the previous costings undertaken by CH2M Hill for Ashely Down and Constable Road. Costs have been provided on a station by station and loop / spur service option basis. A summary table is provided in Section 11. The Estimate output has been used for Economic Evaluation to enable the local authority to prepare their preliminary business case and determine which option(s) are to be progressed.

Ref:	139797
Version:	1.1
Date:	June 2015

Timescales:

2015-2017

- Develop scheme
- Preliminary business case (GRIP 2)
- Outline business case (GRIP 3)

2017-2019

- Detailed technical work (GRIP 4 & 5)
- Planning consent awarded
- Full business case completed
- Funding approval and contractual arrangements finalised
- Construction start (GRIP 6)

2020-2021

- Construction completed

- **2021-2022**

- Records Updates and Project completion (GRIP 7 & 8)

Once the Project moves into the design and build stages (GRIP 5-6), it is planned to complete the works and commission the Project for summer 2021.

Ref:	139797
Version:	1.1
Date:	June 2015

2. Introduction & Route Histories

The WoE Local Enterprise Partnership together with the Executive Members for Transport of the four councils, who collectively comprise the WoE Joint Transport Board, has determined that MetroWest Phase 1 and Phase 2 are its highest priorities for devolved DfT funding.

MetroWest Phase 2 is to review the options for an hourly service on a reopened Henbury line (with capacity for two new stations), along with the possibility of additional stations on the Filton Bank, plus additional service stops at Yate and Weston Milton. This is to support sustainable economic growth in the West of England.

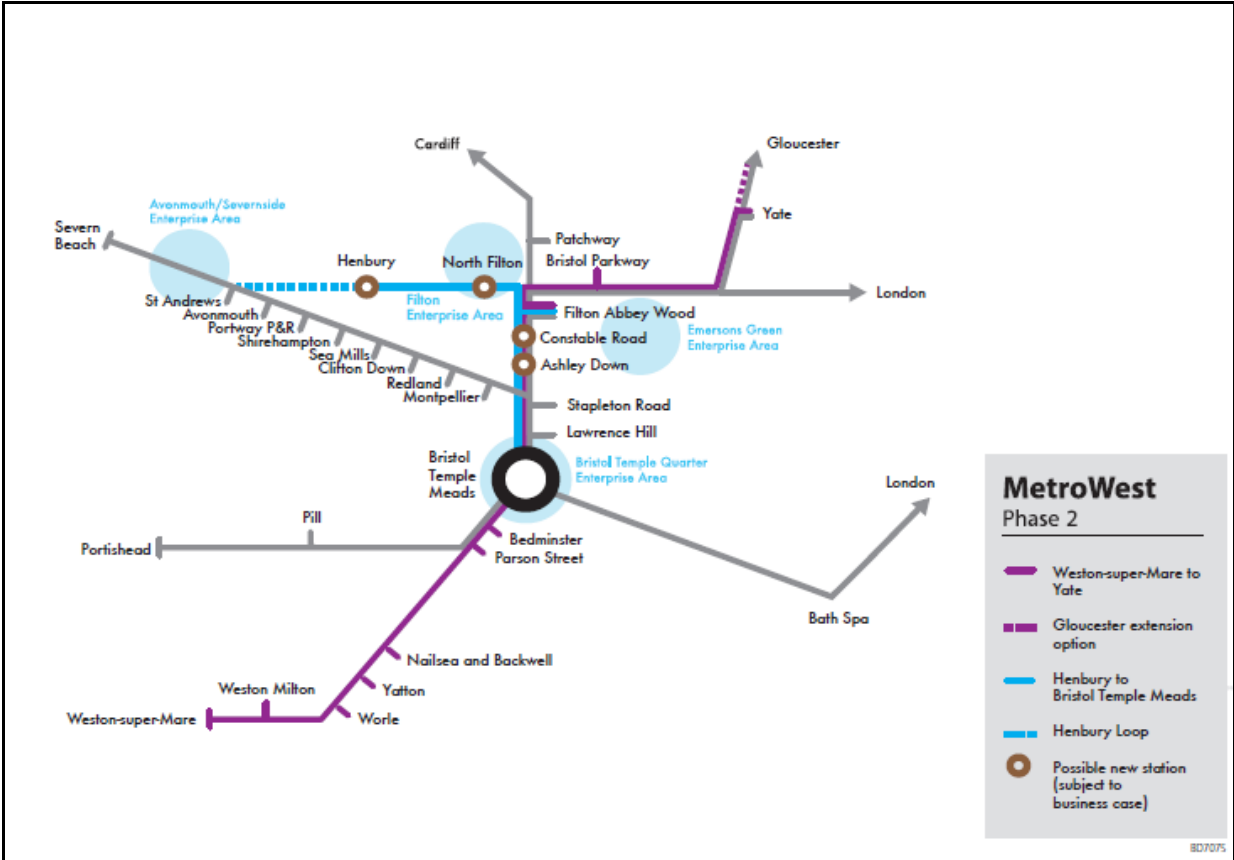

Schematic of proposed Phase 2 routes

Ref:	139797
Version:	1.1
Date:	June 2015

2.1 The Filton Bank Route

Filton Bank is the name given to a section of the rail network in Bristol, roughly between Lawrence Hill and Filton Abbey Wood.



View of Filton Bank Route looking North (area to left will have four tracks reinstated)

The line runs from Dr Days Junction, just south of Lawrence Hill, to Filton Junction, just north of Filton Abbey Wood, via Narrowways Hill Junction. The section is 3 miles 75 chains (6.3 km) long. The bank is largely double track, with sections of triple track around Filton Abbey Wood and from Dr Days Junction to Lawrence Hill.

The line was built by the Bristol and South Wales Union Railway. It was four-tracked until 1984 when it was reduced to double track, with the running lines re-aligned to increase line speeds.

Ref:	139797
Version:	1.1
Date:	June 2015



A 1976 view showing the 4 tracks on Filton Bank

It was announced in July 2012 that four tracks will be reinstated on the Filton Bank. This will restore the separation between fast and stopping services, increasing capacity on the line, which also facilitates half-hourly services along the Severn Beach Line proposed as part of MetroWest Phase 1. The line will be electrified as part of the Great Western Main Line electrification scheme.

In June 2013 this Electrification was confirmed in an announcement on national schemes by the Office of Rail Regulation.

2.2 Ashley Down (formally known as Ashley Hill)

This station is examined in detail in the CH2MHILL report Bristol New Stations – High Level Assessment Study, which can be found in Appendix B, but a brief history of the station is included below for completeness.

Ashley Down is an area in the north of Bristol. It lies on high ground east of Bishopston, north of St Andrews and St Werburghs, west of Muller Road and south of Horfield. The main artery is Ashley Down Road. It is in the Bishopston ward of Bristol City Council.

Ref:	139797
Version:	1.1
Date:	June 2015

Ashley Down was developed in Victorian times. A number of large detached villas were built on Ashley Down Road. Smaller terraced houses were built in the north of the district.

Located close by the former Ashley Hill Station is the home of Gloucestershire County Cricket Club.

Between 1864 and 1964 Ashley Down was served by Ashley Hill railway station.

The station was opened in 1864 by the Bristol and South Wales Union Railway, which was absorbed by the Great Western Railway in 1868. The station passed to the Western Region of British Railways on nationalisation in 1948. It was closed by the British Railways Board in 1964, following the Beeching report.

Trains running between Bristol Temple Meads and Bristol Parkway pass the site. Remains of one of the platforms are clearly visible.

The line through Ashley Hill is due to be electrified by 2017 as part of the Great Western Main Line electrification project. The electrification scheme also includes the four-tracking of Filton Bank.

It was suggested that Ashley Hill station be reopened as part of MetroWest. The reopening is supported by Bristol City Council, local MPs and local rail groups, and would provide rail access to local areas, colleges and the County Cricket Ground.

2.3 Horfield (Constable Road)

The CH2MHILL report also considered two sites for Horfield the former station site and a site near Constable Road, as an additional station on the Filton Bank. The former station site is in an area that will contain new cross overs for the new four-track layout and, hence, it cannot now be developed as a station, CH2MHILL considered an alternative site at Constable Road. Historically, there was no station at the Constable Road site and therefore there is no history to record. However, the review document CH2MHILL report Bristol New Stations – High Level Assessment Study examines the viability of the Constable Road Site. Please refer to Appendices B.

It should be noted that to build and operate any station on the Filton Bank will require approval from Network Rail Head of Track and ultimately from the Railway Safety and Standards Board (RSSB) as the gradient exceeds that specified in the Standard.

2.4 North Filton

North Filton Platform was a railway station which served the northern part of Filton on the outskirts of Bristol. It was on the railway line between Filton and Avonmouth, and was situated on the western side of Gloucester Road (the present A38).

The railway line between Stoke Gifford Junction and Holesmouth Junction (Avonmouth), now known as the Henbury Loop Line, was opened by the Great Western Railway (GWR) on 9 May 1910, together with the Filton West Loop (Filton Junction to Filton West Junction). Among the stations on that line which opened the

Ref:	139797
Version:	1.1
Date:	June 2015

same day was one originally known as Filton Halt, it closed less than five years later, on 22 March 1915, as a wartime economy.

This Halt was reopened in 1926, and was renamed North Filton Platform.

Regular passenger services ceased from 23 November 1964, but official closure did not occur until 12 May 1986.

The proposed redevelopment at Filton Airfield with extensive housing and commercial use will require an improvement to the current transportation network. The adopted South Gloucestershire Core Strategy recommends that a station at North Filton, together with one at Henbury, be re-opened for passenger services to serve the redevelopment area (known as the Cribbs Patchway New Neighbourhood – CPNN).



The existing Freight Route – Filton West Junction to Hallen Marsh Junction and the redundant platforms at North Filton

2.5 Henbury

The town of Henbury is a suburb of Bristol approximately 5 miles north west of the city centre. Henbury is on the railway line between Stoke Gifford Junction and Holesmouth Junction (Avonmouth), now known as the Henbury Loop Line. The line operates as an existing freight route between Filton West Junction and Hallen Marsh Junction on the Severn Beach Line.

The railway line between Stoke Gifford Junction and Holesmouth Junction (Avonmouth), now known as the Henbury Loop Line, was opened by the Great Western Railway (GWR) on 9 May 1910; together with the Filton West Loop (Filton Junction to Filton West Junction) as a more direct route to Avonmouth docks, and was initially known as the Avonmouth and Filton Railway. Although the line was mainly intended for freight services, passenger services were also provided until 1915, with stations at Filton Halt, Charlton, Henbury and Hallen Marsh Junction.

Ref:	139797
Version:	1.1
Date:	June 2015



The former Henbury Station Site viewed from Station Road Overbridge

The line, including Henbury Station, closed to passenger traffic on 23rd November 1964, with goods services being withdrawn from the station as from 5th July 1965. The twin tracked route continues to provide freight access to the Bristol Bulk Handling Terminal at St Andrews Road (Avonmouth).

2.6 Yate

Yate railway station serves the town of Yate in South Gloucestershire, in south west England. The station is located on the main Bristol to Birmingham line between Bristol Parkway and Gloucester, and is operated by First Great Western.



Yate Station

Ref:	139797
Version:	1.1
Date:	June 2015

Yate has two staggered platforms, separated by the A432 road bridge.

Yate station first opened on 8 July 1844 and closed in January 1965, along with other wayside stations on the former Bristol and Gloucester Railway; the local stopping service on the route having been withdrawn. This had both its platforms on the southern side of the road bridge mentioned above - the original 1844 goods shed still stands (now in commercial use) next to the old southbound platform site. The station was reopened on 11 May 1989 with the backing of Avon County Council.

When first open, trains headed south along the original B&GR/Midland route via Fishponds to reach Bristol, although a connection was subsequently laid in to link this route with the rival Great Western Railway's 1903 "Badminton Line" from Wootton Bassett to Patchway (the current South Wales Main Line) in 1908.

The new connection left the older line by means of a flying junction at Yate South before heading southwest to join the SWML at the triangular Westerleigh Junction. Though jointly built by the two companies for the purpose of giving the GWR access to the Severn Rail Bridge and Severn and Wye Railway, it also provided an alternative route to Bristol Temple Meads via Filton. The Great Western Railway soon made use of it to compete with the Midland Railway for Bristol to Birmingham route services. All train services now use this newer line to get to Bristol, as the original 1844 route through Mangotsfield was abandoned in January 1970 following completion of the Bristol area resignalling scheme. A short section of the old route has been retained from Yate South Junction after the remainder closed, to serve a domestic waste transfer depot & fuel oil distribution terminal at Westerleigh sidings. This freight line is currently still in use.

Although currently mothballed Yate remains the junction for the freight only route to Tytherington Quarry. This former branch to Thornbury was closed to passenger services in 1944.

Ref:	139797
Version:	1.1
Date:	June 2015

3. Business Objective

3.1 Problem Identified

The West of England (WoE) sub-region is a net contributor to UK PLC, with the highest economic growth of any core city region (3.1% GVA). However, the sub region's economic prosperity is beginning to be constrained by its transport network. As demand on the transport network increases as a result of economic and population growth, further investment is needed to ensure the transport network is sufficiently accessible and has sufficient capacity and resilience, to continue to meet the sub region's needs. Longer term problems of sustained traffic growth and car dependency also need to be tackled, in addition to wider long term issues of carbon emissions and social wellbeing.

Rail travel across the WoE has doubled in the last ten years and this marks a very clear public appetite to increasingly opt for rail. However, rail travel in the WoE has historically been low compared with similar city regions across England. While the WoE benefits from good long distance rail routes, the local rail network is relatively under-developed. Many of the local rail routes have don't have a basic half hourly peak frequency and some terminate at Bristol Temple Meads, rather than operating across the City region. There are also a number of strategically important disused rail lines and re-opening these lines is a key part of the four WoE councils (Bath & North East Somerset, Bristol City, North Somerset and South Gloucestershire Council) strategy to uplift the local rail network, through the MetroWest programme.

The proposal for MetroWest Phase 2 is being taken forward at a time of considerable investment in the Western Route through Control Period 5 (CP5) 2014-2019:

- electrification of the Great Western Main line;
- strategic enhancement projects to deal with bottlenecks and to increase capacity and renewal projects to modernise infrastructure; and
- MetroWest Phase 1

Ref:	139797
Version:	1.1
Date:	June 2015

3.2 MetroWest Concept

The MetroWest programme will address the core issue of transport network resilience, through targeted investment to increase both the capacity and accessibility of the local rail network. The MetroWest concept is to deliver an enhanced local rail offer for the sub-region comprising:

- Existing and disused rail corridors feeding into Bristol
- Broadly ½ hourly service frequency (but some variations possible pending business case)
- Cross Bristol service patterns i.e. Yate to Weston-super-Mare etc.
- Providing a Metro type service appropriate for a City Region of 1 million population

The programme includes:

- MetroWest Phase 1 - Half hourly local service for the Severn Beach line, Bath to Bristol line and a re-opened Portishead line with stations at Portishead and Pill;
- MetroWest Phase 2 - Half hourly services at Yate plus an hourly service for a re-opened Henbury line, with stations at Henbury, North Filton, and possibly Ashley Down and Horfield.
- Further additional station openings subject to separate business cases; and
- Other potential enhancements including feasibility of extending electrification across the WoE network.

The MetroWest programme is to be delivered over the next ten years during CP5 and CP6 and will also extend the benefits of strategic transport interventions that are either in the process of being delivered or have been delivered by the WoE councils. These include the MetroBus projects, Bath Package, Weston Package and the Local Sustainable Travel Fund programme.

The delivery of these projects together with the MetroWest programme will result in better modal integration between rail, bus and active modes, providing an important step towards seamless modal transfer at key hubs across WoE.

The MetroWest programme has the full backing of the WoE Local Enterprise Partnership. The WoE LEP, together with the Executive Members for Transport of the four councils, who collectively comprise the WoE Joint Transport Board, has determined that MetroWest Phase 1 and Phase 2 are its highest priorities for devolved DfT funding.

Ref:	139797
Version:	1.1
Date:	June 2015

3.3 MetroWest Phase 2

MetroWest Phase 1 compliments planned CP5 investment through targeted investment in the WoE local rail network, to enhance the Severn Beach line, the Bath to Bristol line and re-open the Portishead to Bristol line. MetroWest Phase 2 will play a key role enhancing access to major growth areas including Temple Quarter Enterprise Zone and five Enterprise Areas across the sub-region. The project will bring these major employment centres closer to the skilled workforce catchment, by simultaneously enhancing access to the local train network and enhancing train service frequency. Major employers will have a larger skilled workforce pool to draw on within a 30 minute commute and this will play a part removing barriers to inward investment.

The long term trend of continued traffic growth threatens the WoE's economic prosperity; in response to this the four WoE councils have developed the MetroWest programme as a key part of its integrated 'TravelWest' transport strategy. Key highway corridors into and across the city region are at or near capacity and average vehicle speeds are among the lowest for comparable city regions. The case for intervention to re-balance the transport network, through investment in the local rail network is compelling.

3.4 MetroWest Phase 2 Project Objectives

The principal business objectives of the Project are:

- To support economic growth, through enhancing the transport links to the Filton Enterprise Area, North Fringe, Yate, Temple Quay Enterprise Zone and Bristol City Centre.
- To deliver a more resilient transport offer, providing more attractive and guaranteed (future proofed) journey times for commuters, business and residents in the area, through better utilisation of strategic heavy rail corridors from Yate and Henbury.
- To improve accessibility to the rail network with new and re-opened rail stations and improved service frequencies.
- To make a positive contribution to social wellbeing, life opportunities and improving quality of life (along the affected corridors in particular).

Supporting objectives are:

- To mitigate traffic congestion in the North Fringe and Yate corridor.
- To enhance the carrying capacity of the local rail network.
- To reduce the adverse environmental impacts of the local transport network as a whole.

Ref:	139797
Version:	1.1
Date:	June 2015

4. Business Case

4.1 Business Strategy

MetroWest Phase 2 forms an important part of the West of England's economic growth agenda, led by WoE Local Enterprise Partnership (LEP). The WoE LEP's economic development strategy is being driven by its Strategic Economic Plan (SEP), submitted to Government in March 2014. The SEP together with the City Region Deal (CRD) provide the framework for unlocking growth across the WoE. The SEP and the CRD will deliver the following key outputs:

- Temple Quarter Enterprise Zone (17,000 new jobs);
- Five Enterprise Areas including Bath 'City of Ideas' (9,300), Weston-super-Mare Gateway J21 (11,000), Filton/A38 (4,000) and Avonmouth Severnside (650ha site);
- Ministry of Defence at Filton Abbey Wood;
- The Cribbs Patchway New Neighbourhood - 5,700 homes and 50 ha of employment land at and around Filton Airfield (partly covered by the Enterprise Area);
- 8,000 and 3,000 new homes at Weston-super-Mare and North Yate respectively; and
- Redevelopment of Keynsham Town Centre and Somerdale (former Cadbury's site).

The city region is set for further population growth which is expected to exceed 1.1 million 2026. Planning for this growth means the city region needs to make sure its transport infrastructure is not only fit for purpose, but has the ability to respond to increasing demand, and therefore maximise potential for continued economic growth.

4.2 MetroWest Governance

MetroWest Phase 2 is being promoted by the four WoE councils (Bristol City, North Somerset Bath & North East Somerset and South Gloucestershire Council); the councils have nominated South Gloucestershire as the lead council, supported by the WoE Office. A formal governance structure is in place, including the Rail Programme Board (representatives include Network Rail and First Great Western), along with the Programme Assurance Board having an oversight role.

The Boards report to the WoE Joint Transport Board, which comprise of the four Executive Members for Transport and representatives of the WoE Local Enterprise Partnership. The WoE Joint Transport Board is the strategic decision maker and directs the MetroWest project, determines options and allocates resources and funding, including devolved DfT transport funding. The WoE Joint Transport Board has identified its strategic programme and determined that MetroWest Phase 1 and 2 are its highest priority for allocation of devolved DfT capital funding.

Ref:	139797
Version:	1.1
Date:	June 2015

4.3 Business Case Approach

The MetroWest Phase 2 business case is being prepared using the Transport Five Case Model, in accordance with the DfT's WebTAG framework. The five cases comprise; Strategic case, Economic case, Delivery case, Finance case and Commercial case. The Business Case has to:

- address the project objectives and set out wider context about why the intervention is needed – the **Strategic Case**
- provide a good investment and offer effective use of public sector funds - the **Economic Case**
- show deliverability and robustness – the **Delivery Case**
- be affordable to the Councils both capital and revenue / train service subsidy - the **Finance Case**
- have a sound commercial footing and robust procurement arrangements - the **Commercial Case**

The business case is being prepared by the WoE councils with inputs from Network Rail (including this report); it follows the methodology used by MetroWest Phase 1.

4.4 Business Case Approach

The business case is being developed in three stages; Preliminary Business Case, Outline Business Case and Full Business Case. The Preliminary Business Case is needed for allocation of resources for the development of the project and to inform decision making on the train service option to be taken through to delivery. The Outline Business Case is undertaken to support all requisite statutory processes. The Full Business Case follows procurement of construction works and operational arrangements including the train service and confirms the total cost of delivering the project.

4.5 Business Case Timescales

At the time of writing, the Preliminary Business Case is under preparation and is scheduled to be submitted to the WoE Joint Transport Board in June or July 2015. Each stage of the business case is being taken forward in parallel with the respective GRIP stage, as follows:

- Preliminary Business Case – including GRIP2;
- Outline Business Case including GRIP 3;
- Full Business Case including GRIP 4 & 5.

Construction (GRIP6) is programmed to commence in 2020 and train services to start in the summer of 2021; with project close-out and handover (GRIP 7 & 8) thereafter.

Ref:	139797
Version:	1.1
Date:	June 2015

5. Project Scope

The project is a third party project promoted and funded by the WoE Councils. The project proposal is to review the options for an hourly passenger service on the current freight only Henbury line (with capacity for two new stations), along with the possibility of additional stations at Ashley Down and Constable Road.

The MetroWest Phase 2 project is to:

- Deliver a reliable public transport service operating half hourly train services from Weston-super-Mare to Yate via Bristol Parkway, and hourly services on the Henbury line (capacity for two new stations) with additional station(s) on Filton Bank.
- Ensure freight operations and pathing rights are not jeopardised
- Take into consideration other West of England Partnership proposals, such as interaction with Bus Rapid Transport (BRT)
- The scheme is not to be detrimental to future cross Bristol services such as MetroWest Phase 1 and potential future services
- Be delivered in collaboration between Network Rail and the WoE Councils, subject to business case, powers to build and operate and allocation of funding.

Ref:	139797
Version:	1.1
Date:	June 2015

6. Deliverables

This feasibility report is based on the extension of the Phase 1 work (reinstatement of passenger services to Portishead) that has been completed to date. This report will consider:

- The provision of track and signalling infrastructure at Yate, to permit the turnback of services from Weston-super-Mare.
- New stations at North Filton and Henbury on the Avonmouth & Filton line (AFR)
- Options to enable passenger services to operate to Henbury:
 - A loop line service via Avonmouth and Filton Bank and the impact on the Seven Beach Line
 - A spur line via Filton Bank with passenger services terminating at Henbury and returning to Bristol
 - A review of an existing draft feasibility report for potential stations at Ashley Down and Constable Road on the Filton Bank
- Upgrading the existing freight lines to passenger status.
- Remodelling of Hallen Marsh Junction to permit passenger services on a Henbury loop service to access the Severn Beach Line
- Provide Station layouts which integrate with proposed development master plans
- Level Crossings impact assessment
- Signalling modifications as required
- Review track at St Andrews Road Level Crossing
- Environmental Appraisal
- Location of pathways and cycle ways

Ref:	139797
Version:	1.1
Date:	June 2015

7. Options Considered

7.1 Services to Henbury

This report considers two operating scenarios to provide passenger services on the Henbury line, a loop service and a spur service. It also examines a single option for a new station at North Filton and two locations for a new station at Henbury.

The proposed station layouts at Henbury will be different for the loop and spur options therefore there is a total of four options for the new Henbury station being considered;

- 1a. - Eastern new station location, spur service.
- 1b. - Eastern new station location, loop service.
- 2a. - Western former station location, spur service.
- 2b. - Western former station location, loop service.

7.1.1 Station Location Options

North Filton Station Site

This is the site of the historic North Filton Station adjacent to Filton Airfield and the A38, it is the location preferred by the Local Authority and the developer of the Airfield (BAE).

1. New Henbury Station Site (Eastern Location)

This is a Greenfield site to the east of the A4018 Wyck Beck Road, the proposed station would be to the North of the Railway. The developer of land north of and adjacent to this site has included a station in its outline planning application.

2. Historic Henbury Station site (Western Location)

This is the site of the historic Henbury station, it would utilise the historic location of the platforms but the station access, car park and other infrastructure would be located to the North of the railway (the historic station vehicular access and buildings is to the south of the railway). The developer of land north of and adjacent to this site has included a station in its outline planning application.

Ref:	139797
Version:	1.1
Date:	June 2015

7.1.2 Service Options

a. Spur service

The spur service operating scenario is an hourly out and back service from Bristol Temple Meads to Henbury via the Filton Bank, Filton West Chord and the AFR line.

b. Loop Service

The loop service operating scenario is an hourly bi directional circular route between Bristol Temple Meads, via the Filton Bank, Filton West Chord, Henbury, Avonmouth Clifton Down and Temple Meads.

7.2 Provision for the Turnback of Services at Yate

There are several ways of providing turnback facilities at Yate using existing and enhanced infrastructure. What has been termed the “short turnaround” scenario (trains arrive at and depart from the same platform without moving to a layover siding) can be achieved on either of the existing platforms with little infrastructure change. There is also an option to run services to/from Gloucester, which would require no changes at Yate; however, at the time of writing, the full cost-benefit analysis for this option has yet to be concluded.

The operational modelling has determined that under the “short turnaround” scenario there is risk to through services at Yate if inbound services from Weston-super-Mare are delayed. To mitigate this risk the following “long turnaround” options have also been considered whereby trains move to a layover siding before returning to Weston-super-Mare.

- Inbound services from Weston-super-Mare terminate in Platform 1 (Up Charfield) and then move onto the Tytherington branch to layover. Trains returning to Weston-super-Mare would pull out of the Tytherington branch; pick up passengers from Platform 1 and use a new crossover from the Up to Down Charfield at the south end of the station, to continue southwards.
- As an alternative to the above, trains returning to Weston-super-Mare could exit the Tytherington branch and via a reverse shunt over an existing crossover to the south of the station, pick up passengers from platform 2 before setting off to the south.
- Inbound services from Weston-super-Mare terminate in Platform 2 (Down Charfield) and then move onto a new turnback siding, north of the station, to layover. Trains returning to Weston-super-Mare would pull out from the turnback siding and depart southwards from Platform 2

The selection and detail of the preferred option is discussed in section 8.6.

Ref:	139797
Version:	1.1
Date:	June 2015

8. Engineering Options – General Considerations

8.1 General

URS have provided a multi-disciplinary approach providing Track, Civil, Electrical & Power, Telecom and Environmental design inputs to the proposals, with the Network Rail (NR) Signal Design Group (SDG) providing the signalling design input.

The designers have worked within the constraints of the relevant NR and Highways Agency design codes and best practice whilst adhering to the remit and guidance provided by the various stakeholders.

The Buried services information provided by Network Rail has been reviewed and no major obstacles to the project being found. However, as the project moves through the GRIP stages and is developed further into outline and detailed design further buried services reviews will need to be carried out to ensure that the final locations of structures do not clash with existing underground services or where required suitable service diversions are provided.

8.2 Land Ownership

At all station locations land ownership is a critical requirement of the option development process. This is to ensure the preferred option can be justified and the full requirements for third party land and rights over land can be included in the planning application(s). The optioneering process must include identification of the land required for construction, operation of the station, land required for new utilities and changes to existing utilities, drainage, and land required for pedestrian, cars, HGVs, and cycle access etc.

When the preferred option has been identified land ownership can be confirmed by the land referencing team.

Failure to identify all the land required to construct and operate the project is likely to result in insufficient powers to build the scheme.

It is currently assumed that land will only be required outside Network Rail ownership at the proposed station locations.

8.3 Statutory Powers

We understand the statutory powers for this MetroWest scheme will be sought via Permitted Development Rights and Planning Consents and/or TWAO.

8.4 Rights of Way

Public rights of way to be investigated at GRIP Stage 3.

Ref:	139797
Version:	1.1
Date:	June 2015

9. Engineering Options

9.1 Ashley Down

Ashley Down is in the vicinity of the former Ashley Hill Station adjacent to Station Road with a cycle path passing under the Railway and the Concorde Cycle Path running alongside the Railway to the West at this location. It is proposed that the Railway is increased to four tracks as part of the Filton Bank four tracking project. This would reinstate the former arrangement of main and relief lines on the Filton Bank with the main lines lying to the East and the relief lines lying to the West. It is proposed that the Platforms for Ashley Down would be provided to the relief lines only. For further details please refer to CH2MHILL report in Appendices B. It should be noted that a station at Ashley Down would require a derogation to deviate from Railway Group Standards to build and operate a station(s) on a 1:75 gradient.

9.2 Constable Road

This is a new station site in the vicinity of Constable Road with vehicular access through a small industrial estate off of Romney Avenue. For further details please refer to CH2MHILL report in Appendices B. A new station at Constable Road would require a derogation to deviate from Railway Group Standards to build and operate a station(s) on a 1:75 gradient.

9.3 North Filton

The arrangements at this station would be the same for the spur and loop options.

Track

The potential arrangements at the provision of a station at North Filton are shown on URS drawing No. 47072043-SW-PW-DRG-7003 included in Appendix J.

The site of the proposed station at North Filton is centred at 113m 14ch on the AFR route between Bristol Parkway and Hallen Marsh Junction on the Severn Beach (AMB) route. This location is the site of the former North Filton Platform which comprised two single-faced platforms, one either side of the Up & Down Branch lines.

Both the loop and the spur operating scenarios require the two single faced platforms and neither scenario requires any new switch and crossing layouts to be installed.

The horizontal alignment of both the Up and Down Branch lines at the site is straight and would require design lining over the extent of the proposed platforms. This would regularise the track geometry and intervals to facilitate coping edge installation. Notwithstanding the drainage issues referenced below the track components (flat bottomed CWR on concrete) are acceptable for the existing and proposed 60 mph linespeeds at the site.

Ref:	139797
Version:	1.1
Date:	June 2015

At the site, the Up Branch line in particular, suffers from a saturated sub-grade and ballast profile with attendant slurry pumping issues. A relatively recent drainage installation has not fully mitigated this problem and Network Rail have a further proposal to lift the Up Branch by up to 150mm during 2015/16. Such a lift would inevitably mean that even if the vertical platform walls of the former station could be incorporated in the design of the new platforms then the oversailing and coper edgings would still require significant alteration. A very comprehensive topographical survey and platform gauging exercise would be required to establish any possibility of embedding elements of the former platforms within the new proposals.

A longitudinal gradient of approx. 1 in 210, falling from west to east, applies at the site of the proposed platforms. This is considerably steeper than the recommended maximum gradient of 1-500 set out in Railway Group Standards for platform longitudinal gradients. There is a recognised process for the identification of risks associated with platform gradients steeper than 1 in 500 and if the existing gradient were to be incorporated in the platform design then this process would be invoked. The fact that neither the loop nor the spur operating scenarios would involve units being turned back in either of the single faced platforms would somewhat de-risk the gradient issue.

As an alternative to seeking derogation from Railway Group Standards, for platforms steeper than a 1 in 500 gradient, consideration could be given to a revision of the track vertical profile. Using the track at the western end of the proposed platforms as a point of zero change, the twin tracks would need to be progressively lifted towards the east by up to 350mm to create the 1 in 500 track gradient. This track lift could cause clearance issues under the New Road and A38 overbridges. Furthermore there will be a need to correspondingly steepen the falling gradient to the east to compensate for the 350mm lift and this would seriously impact on the Filton West Junctions.

Civils

Refer to URS drawing No. 47072043-SW-CV-DRG-0001 included in Appendix J.

The proposal is for an unmanned local station category F1 with two platforms serving the existing up and down branch lines. These will be linked by a footbridge with stairs and DDA compliant ramps. The footbridge would be a steel structure based on NR standard details and may require piled foundations.

The station will have a vehicle access via the CPNN Filton Airfield re-development. The station car park will include a bus stop, car parking for 30 cars plus 3 disabled spaces and cycle rack spaces. It is proposed that the station will be served by the Cribbs Patchway MetroBus Extension. The proposed car park layout is a concept design only as the road layout for the new Filton Airfield re-development is yet to be finalised.

The existing platforms are of a much greater length than those proposed by this project and extend either side of the BAE Systems (Airbus) access bridge. For this project it was decided to locate the new platforms to the west of the Airbus access bridge. The platforms will be designed for 4 car train units, 101m long plus a 25m passive provision for 5 car units. Each platform will have a waiting shelter and two benches. It may be possible to retain the existing platform walls subject to surveys

Ref:	139797
Version:	1.1
Date:	June 2015

however it is expected that the minimum works required will involve new oversail blocks, copers and surfacing, along with new platform drainage. Foundations will need to be provided for the various items of platform infrastructure.

The CH2MHILL report shows access ramps down to the platform from the Airbus overbridge to provide the DDA complaint access. This was considered over complicated and the proposal now shows a separate footbridge with ramps and stairs to the platforms and a short ramp and staircase to the car park level (the car park is at a higher level than the platforms due to the railway passing through a shallow cutting at this location). The proposal for the station also includes a new footpath connecting it to the A38 which forms part of the wider foot/cycle path network to North Bristol and South Gloucestershire.

The new platforms will require drainage channels to the rear edge. These channels will discharge into adjacent track drainage where present. If track drainage is not present then a suitable soak away will be provided.

The new station car park will be provided with a suitable SUDS compliant soak away, subject to geotechnical investigations. Should these investigations prove that the conditions are not suitable for a soak away then a connection to the local sewer system and the associated consents will be required.

Drawing 47072043-SW-CV-DRG-0001 in appendix J shows a proposal for the layout of the station.

Telecoms

Station Information & Surveillance Systems (SISS)

The most efficient method of providing modern Station Information & Surveillance Systems (SISS) for small stations is to provide an IP (internet protocol) based solution. This allows all systems to be connected to a common station switch which uses a single connection to the outside world. All systems are housed in a single, centrally positioned, equipment cabinet and powered from a single 230 volt DNO supply supported by an Uninterruptable Power Supply (UPS) to provide a 1-hour back up for the CCTV system.

The generic diagram below gives a typical system schematic for a small station scenario.

Ref:	139797
Version:	1.1
Date:	June 2015

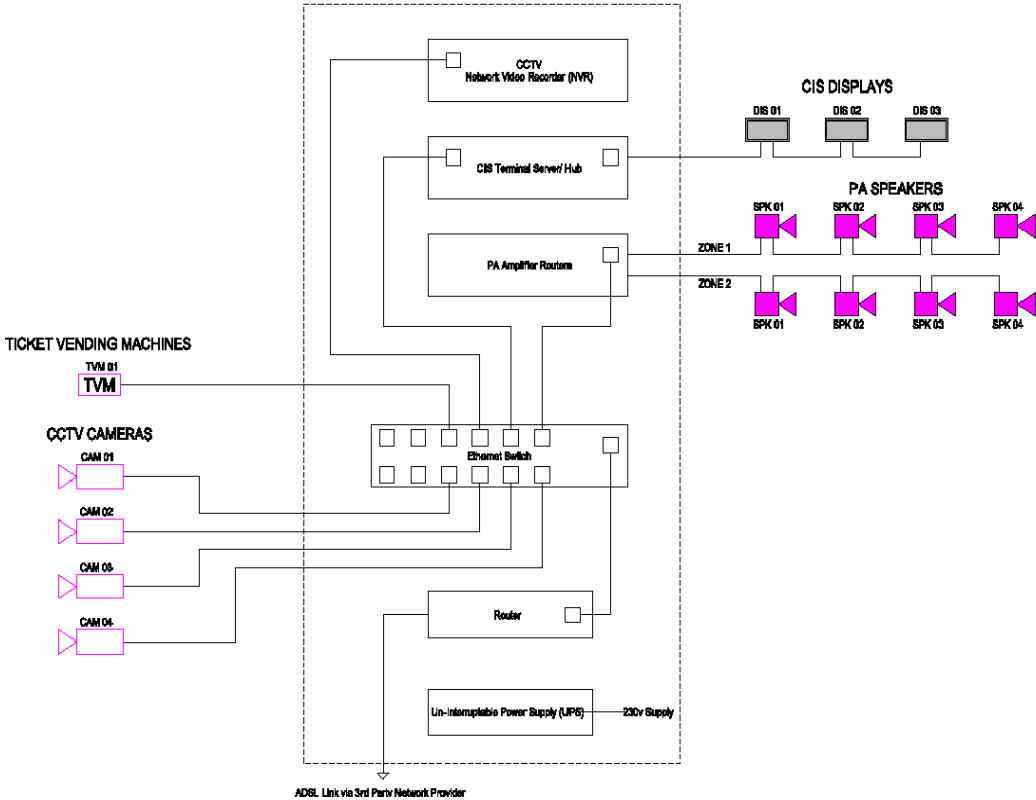

Operational Telecommunications

For small stations, the extent of operational telecommunications will be limited to the provision of telephones associated with the signalling systems and the management of the lineside cable route.

Closed Circuit Television (CCTV)

All CCTV systems on the railway are to be designed for the purpose of providing general monitoring of the station and to offer a means of protecting the safety and security of the public and where applicable, staff working on the station. Any system provided at North Filton Station, shall be compliant with Network Rail Standard NR/L2/TEL/30135 and developed with the Train Operating Company (TOC), British Transport Police (BTP) and other interested parties.

The system shall be designed for general monitoring of the stations, particularly entrances / exits and will offer a means of enhancing the safety and security of the public, staff and the general management of the station.

The system shall make provision to include 24 hour surveillance of the station car parking facilities. The cameras shall be suitable for both day and night operation, maintaining a good quality level of coverage, even when the light levels diminish.

CCTV images shall be recorded locally on a Networked Video Recorder (NVR). The system shall be designed to enable monitoring and recovery of recorded images from a remote location.

Ref:	139797
Version:	1.1
Date:	June 2015

The use of Internet Protocol (IP) cameras is recommended. These cameras can be operated and powered directly from the station Ethernet Switch via CAT6 cables up to a maximum distance of 90 metres. This will require the equipment cabinet to be located centrally for maximum flexibility. Cameras beyond 90 metres can be fed using CAT6 line extenders. An Ethernet Switch, capable of providing Power over Ethernet (PoE), must be used to satisfy the above. A total of 22 cameras are recommended to meet the current Network Rail Specification.

Public Address (PA)

A PA system is recommended to broadcast secure, high intelligibility speech to all public areas on station platforms; this may include pedestrian access areas to the platforms if required. The requirements for the new PA system shall be compliant with Network Rail Standard NR/L2/TEL/30134 and as agreed with the Train Operating Company (TOC). It is recommended that an acoustic survey and modelling of the PA catchment areas be undertaken, to ensure that environmental noise is kept to a minimum and therefore reduce the impact on the neighbouring residents.

In order to instigate and update the announcements and for fault reporting, a link from the local PA control equipment at the station, to the associated TOC Control Centre will be achieved via the Station Ethernet switch.

To aid passengers with hearing difficulties, the PA system must include an integrated Induction Loop facility. A total of 18 speakers are recommended to meet the current Network Rail Specification.

Customer Information Systems (CIS)

A Customer Information System is recommended, delivering live train information to the travelling public both for passengers in transit from the station car park and those waiting on the station platforms.

The requirements for the new CIS system shall be compliant with Network Rail Standard NR/L2/TEL/30130 and as agreed with the TOC.

In order to instigate and update the train information displayed, a link from the local CIS control equipment at the station, to the associated TOC Control Centre will be achieved via the Station Ethernet switch. A total of 5 displays are recommended to meet the current Network Rail Specification.

Passenger Help Points (PHP)

Passenger Help Points are recommended as a focal point for information and in the event of an emergency.

It is proposed that the PHPs be GSM (mobile) enabled, this will allow installation and operation regardless of the availability of local rail telecommunications infrastructure. This can also be achieved via a more traditional leased line from a third party provider. This decision will be in consultation with the TOC

Ref:	139797
Version:	1.1
Date:	June 2015

PHPs shall be a two button type unit with one button marked 'Information', the second 'Emergency'. Calls are routed via the GSM provider or, in the case of a leased line, the Public Switched Telephone Network (PSTN) to the information call centre. A total of 2 PHP's are recommended (1 per platform).

To aid passengers with hearing difficulties, the PHP shall include an Induction Loop facility, integrated within the passenger help point enclosure.

Ticket Vending Machine

Two Ticket Vending Machines will be provided. Each ticket machine works independently but uses a telecommunications data link to upload sales information and transactions to its main control. This data link is provided from the main station switch housed in the telecommunications equipment cabinet.

Telecommunication Equipment Cabinet

An equipment cabinet, designed for external use, is recommended to house the Power, Ethernet Switch & Router, CCTV, PA and CIS control equipment. This will need to be located in a high street environment and in a central position that provides unhindered access for maintenance purposes. A standard mains 230 volt supply will need to be provided.

Given the amount of sensitive equipment installed it is recommended that a cabinet with thermal management and EMC protection is provided to prevent any issue associated with extreme temperature excursions and electrical interference.

Third Party Connections

A third party Asynchronous Digital Subscriber Line (ADSL) connection will be required at North Filton Station.

This third party connection will allow the Station Ethernet switch to be connected, via the station router, to the TOC control centre in order to provide updated information for all SISS systems.

Local Cable Routes

All the SISS systems mentioned above will require a local cable route from the equipment to the centralised equipment cabinet. A platform duct route is recommended with a centrally located under track crossing (UTX) for access to the other platform.

Ref:	139797
Version:	1.1
Date:	June 2015

Operational Telecommunications

Lineside Telephony:

It is assumed that there are to be starting signals on the ends of station platforms; therefore there may be a requirement for Signal Post Telephones (SPTs) associated with each signal. The position of the telephone will be determined by the signal sighting committee at a later GRIP Stage.

The existing line side cable infrastructure shall be used to connect the operational telephones to the controlling Signal Box. This will require a full survey at a later GRIP Stage to determine the capacity, condition, location and connection points of the existing cable infrastructure. Should the existing infrastructure prove not fit for purpose, then other options must be considered for operational connectivity, these may include;

1. Provide new line-side cable infrastructure,
2. Remodelling of existing cable infrastructure,
3. Leasing 3rd party circuits,
4. Provision of IP operational telephones via the Station Ethernet Switch (subject to Network Rail approval).

A similar survey must be undertaken to establish the condition and capacity of the telephone concentrator at the controlling Signal Box. If sufficient capacity exists then this can be used for any additional operational telephones provided by this project. Should there be insufficient capacity, then an upgrade or replacement of the telephone concentrator must be considered.

Existing Lineside Cable Route:

The building of new stations, or the rebuilding of old, will impact on the position of the line-side cable route. This is a particular issue at the North Filton site where the existing cable route goes through the old UP platform. It is important that where such cable routes exist, that these are diverted and/or fully protected during the station construction phase.

During the station design phase, provision must be made for a fully re-instated, fit-for-purpose cable route that affords unhindered access to the installer and maintainer alike.

GSM-R

From current data, there is no GSM-R infrastructure that would be affected by any proposed works. There will however be a requirement to update the GSM-R database as a result of this project.

Ref:	139797
Version:	1.1
Date:	June 2015

SPT Provisions

1X SPT relocated, associated with signal BL1834.

Signalling

Refer to the Network Rail Signalling Design Group (SDG) Signalling Feasibility Report listed in Appendix H.

Environment

The land to the north (Filton Airfield) is currently owned by BAE Systems, and proposals for a new station are included in the developer's outline planning application, which can be found on the South Gloucestershire Council website (ref PT14/3867/O):-

<http://www.southglos.gov.uk/environment-and-planning/search-planning-applications/>

The outline planning application for the site has been submitted to South Gloucestershire Council for determination in 2015.

The station design and access (pedestrian, public transport and cars) should be carried out in accord with the CPNN SPD and the Filton Airfield planning consent(s). A full Traffic and transportation assessment will be required, starting at GRIP 3 to inform the options and station design and to ensure full integration with the consents.

There is an area of mature trees and scrub that would need to be removed for the station to be constructed and it is assumed an ecological assessment will be carried out as part of the Environmental Impact Assessment (EIA). Based on the site visit there are no obvious other sensitive environment receptors close by. Station design and landscaping should take into account the master plan proposals and incorporate design principals and proposed environmental mitigation.

The requirements for utilities at the station and the proximity of existing utilities need to be taken into account during GRIP 4 to ensure they are assessed and the necessary consents and wayleaves identified.

Refer to Appendix G for Environmental Appraisal.

Electrical / Utilities

It is proposed that a new DNO supply will be installed. The DNO cubicle will be positioned in close proximity to the station adjacent to a fenced area which is easily accessible. The DNO cubicle will be double sided. One side would consist of DNO equipment and a meter, accessed on the public side of the fence thus allowing for straight forward meter reading and necessary maintenance. The second railway side of the cubicle would contain the distribution and lighting control systems and would be easily accessible by rail staff. A pedestrian gate adjacent to the DNO cubicle might be necessary.

Ref:	139797
Version:	1.1
Date:	June 2015

The lighting of the platform would need to comply with Railway Group Standards GI/RT/7016 and RIS-7702-INS and therefore should achieve a maintained horizontal minimum of 20Lux with a minimum uniformity of 0.4. This is consistent with driver only operated (DOO) stations. The vertical illuminance at a height of 1m to the platform surface at the edge of the platform will need to be 6Lux for DOO stations. However, the RIS standard mentions that lighting should be developed to any task that might be undertaken on the platform and if there are any tasks that require a certain level of detail to be completed the Lux levels will need to be revised relevant to that task.

In order to comply with the DDA, the lighting of the station needs to be taken into consideration. Therefore for the platform ramp/stairs the lighting level should achieve a minimum of 100lux and the DfT Code of practice does not give minimum Lux levels or uniformity so this would be in line with the 0.4 requirement of RIS-7702-INS. Usually DDA requirements are not applied to platform areas with the group standard values being adopted. For a ticket counter or ticket machine a minimum of 300Lux with a uniformity of 0.5 will be required.

The luminaries for the platform are shown to be 5m above the platform and are at 10m spacing's. This is based on the guidance applied by the manufacturers that set out the maximum distance between luminaires is twice the height of the column. From past experience it should be possible to attain the required illuminance levels. The heights and spacing's for the proposed luminaires will be confirmed at the GRIP 3 stage of the project by calculation either by hand or by an employer approved calculation package. The use of raise and lower columns mean that the maintenance staff can carry out maintenance and repair at platform level. It is proposed that the raise and lower jack be kept in the vicinity of the station where it can be safely stored.

The waiting shelter is assumed to be a transparent or translucent type structure that will not require separate lighting requirements and the platform lighting will provide enough lighting for its use. However this is to be confirmed during the GRIP 3 stage of the project and if an opaque shelter is to be used then the lighting inside the shelter shall be to, as a minimum, the same level as the platform and the control of the lighting will be tied into the platform lighting control system.

The supplies for the telecoms equipment such as Customer Information System (CIS), Close Circuit Television and Public Announcement will be feed from the station distribution board located in the confines of the DNO (distribution side) cubicle.

It has been assumed that a gas and water supply is not required for the station.

Car parks will need to be lit in accordance with BS 5489-1 and be a minimum of 5Lux with a uniformity of 0.25. However the DfT Code of practice does not give any guidance on car parking areas for DDA requirements, however if DDA requirements are to be applied in the car park then it is recommended that a minimum of 100Lux with a uniformity of 0.25 be applied

For indicative purposes only, 5m columns with luminaires have been shown with a typical 10m spacing. Double headed lighting columns have been used where necessary and flat glass luminaires are proposed to reduce glare and light pollution. Where car park lighting columns are in vulnerable positions collision protection would be provided

Ref:	139797
Version:	1.1
Date:	June 2015

Cycle Paths

Currently there are no cycle paths serving this location, however the station concept design includes a path from the station to the A38 which forms part of the wider cycle way network of North Bristol and South Gloucestershire, and this could form part of any future cycle route to the station.

Access Points

The former Brabazon crossing is to be removed; this would create an ideal opportunity to provide a road/rail access point (RRAP) from the adjacent proposed commercial area.

Fencing / Security

The new station would require suitable fencing and security to separate the public from the railway; this will need to be designed with consideration being given to high level of development taking place in the area and how this will impact on the risk from vandalism and crime.

The British Transport Police would be given the opportunity to advise on security, trespass and anti-vandalism measures at later stages of the GRIP process.

Structures

These proposals do not affect any of the adjacent structures.

Bridge Clearance

During detailed design topographical surveys will be carried out on the station sites. This will include the recording of clearances to both the Airbus access road and A38 overbridges. This will provide the basis for designs that can accommodate relevant freight and passenger services. This gauging survey would also confirm the clearances available for overhead line electrification.

9.4 Henbury Option 1 (Eastern 'New' Station Location)

A new location at 115m 12 ch – immediately to the east of the A4018 Wyck Beck Road overbridge and adjacent to proposed CPNN residential development. The station configuration for a spur service would be different from that for a loop as discussed below.

Track

The arrangements at the potential new station site to the east of the A4018 Wyck Beck Road are shown on URS drawing No. 47072043-SW-PW-DRG-7001 included in Appendix I.

Ref:	139797
Version:	1.1
Date:	June 2015

Spur Services (Option 1A)

The track infrastructure required to support this option requires a new Down to Up Branch facing crossover and a new turnout in the Up Branch line leading to a bay platform line. The new crossover is best located on concentric RH curves centred around 114m 76ch. The length of existing straight to the west of proposed curved location for the crossover has insufficient length for both the crossover and the turnout to the bay platform line.

A Dvs 15, 25 mph RH layout would provide a 25 mph crossover move at this location.

A Cvs 13 RH out of straight turnout would provide a 25 mph connection to the bay platform line. The switch toes of this turnout would be at 115m 2 ch on a straight element of track between reverse curves.

The bay platform line itself would be formed from new flat bottomed CWR on steel or concrete sleepers. The signalling arrangements are such that there is no requirement for any trapping/friction stop block protection at the exit from the bay platform onto the Up Branch line. At the termination of the bay line a friction stop block would be provided with deceleration characteristics appropriate for the speed and weight of the proposed DMU services. Although the through lines at this location fall from east to west at a gradient of approx. 1 in 120 the bay line and attendant platform would be constructed to a level gradient and a straight horizontal alignment.

The bay platform line has been located at sufficient interval from the existing Up Branch line to permit the construction of a single faced platform adjacent to the Up Branch should the spur operating scenario be replaced with a loop service at a later date.

The current trackform at this location comprises flat bottomed CWR with concrete sleepers on the Up Branch and steel sleepers on the Down Branch. The linespeed is 60 m.p.h. on both lines and the top and line characteristics are perfectly adequate for these speeds. In addition to the installation of the new crossover/turnout and the bay platform line, design lining should be undertaken between 114m 70c and 115m 18c to regularise the track geometry.

Loop Services (Option 1B)

To support loop services at this location the construction of two single faced platforms adjacent to the Up and Down Branch lines is required. No new switch and crossing layouts are required for this operating scenario but it is recommended that the existing Branch lines are design lined through the proposed platform areas to regularise the track geometry and intervals.

The twin tracks at the proposed platform locations are aligned with elements of concentric LH circular curve (facing high mileage) of approx. 1210m radius, transition curves and straights. Inevitably the proposed platforms would follow the curvature of the track. The provision and maintenance of acceptable platform passing clearances/steeping distances would be a key element of the design proposal.

A longitudinal gradient of approx. 1 in 120, falling from east to west, applies at the site of the proposed platforms. This is considerably steeper than the recommended

Ref:	139797
Version:	1.1
Date:	June 2015

maximum gradient of 1-500 set out in Railway Group Standards for platform longitudinal gradients. There is a recognised process for the identification of risks associated with platform gradients steeper than 1 in 500 and if the loop operation scenario is identified as the preferred option then this process would be invoked. The fact that the loop service scenario would not involve units being turned back in either of the single faced platforms would somewhat de-risk this option.

As an alternative to seeking derogation from Railway Group Standards for platforms steeper than 1 in 500, consideration could be given to a revision of the track vertical profile to create a gradient of at least 1 in 500. Using the Wyck Beck road overbridge as the point of no change the track would need to be progressively lowered to the east for a distance of some 130m (5 car standage) to create a 1 in 500 gradient. A minimum lowering of approx. 850mm would be required to achieve 1 in 500 over this extent and there would need to be a corresponding steepening of the gradient to the east to compensate for the lowering. This is a very substantial lowering and the investigation of sub-grade conditions, the need for cess lowering, track drainage and the undermining of lineside structures would all require outline design and costing.

Should the loop operating scenario emerge as the preferred option then both the derogation route and the revised vertical profile would require detailed consideration.

The current trackform at this location comprises flat bottomed CWR with concrete sleepers on the Up Branch and steel sleepers on the Down Branch. The linespeed is 60 m.p.h. on both lines and the top and line characteristics are perfectly adequate for these speeds.

Civils

Refer to URS drawing No. 47072043-SW-CV-DRG-0002 / 47072043-SW-CV-DRG-0003 included in Appendix J

This is currently a green field site adjacent to the A4018 (Wyck Beck Road). It is proposed to provide station facilities to the North of the railway with road connections to the forthcoming CPNN Filton Airfield re-development and then onto the A4018.

Option 1A (the spur service) will provide a single new platform which will be constructed with a straight and level alignment, to the north of the railway. An area between the new platform and the existing railway would provide passive provision for construction of a platform to serve the branch line if a loop service was introduced. The new platform will be designed for 4 train car units, 101m long plus a 25m passive provision for 5 car units, the platform will have a waiting shelter and two benches.

If Option 1B (the loop service) is selected then two new platforms will be required. They would have an alignment which is curved and on a gradient. The new platforms will be designed for 4 cars, 101m long plus a 25m passive provision for 5 car units. Each platform will have a waiting shelter and two benches. This option will also require a footbridge to link the new platforms, which will be a steel structure based on NR standard details and may require piled foundations.

Ref:	139797
Version:	1.1
Date:	June 2015

The new station would have a vehicle access with curve radii to enable the use of buses, car parking for 30 cars plus 3 disabled spaces, a bus stop and cycle racks spaces.

The new platforms will require drainage channels to the rear edge. These channels will discharge into adjacent track drainage where present. If track drainage is not present then a suitable soak away will be provided.

The new station car park will be provided with a suitable SUDS compliant soak away, subject to geotechnical investigations. Should these investigations prove that the conditions are not suitable for a soak away then a connection to the local sewer system and the associated consents will be required.

A 3 metre wide footpath with low level bollard lighting is to be provided from Tranmere Avenue to the southern side footbridge access, and a further 6 cycle rack spaces will be provided.

Telecoms

Station Information & Surveillance Systems (SISS)

Refer to Henbury Western location below.

Operational Telecommunications

Refer to Henbury Western location below.

Closed Circuit Television (CCTV)

Refer to Henbury Western location above. The following camera quantities for each option are recommended to meet the current Network Rail Specification for this site:

- 1a. 16
- 1b. 32

Public Address (PA)

Refer to Henbury Western location above. The following speaker quantities for each option are recommended to meet the current Network Rail Specification for this site:

- 1a. 10
- 1b. 20

Customer Information Systems (CIS)

Refer to Henbury Western location above. The following display quantities for each option are recommended to meet the current Network Rail Specification for this site:

- 1a. 2
- 1b. 4

Ref:	139797
Version:	1.1
Date:	June 2015

Passenger Help Points (PHP)

Refer to Henbury Western location below.

Ticket Vending Machine

Refer to Henbury Western location below.

Telecommunication Equipment Cabinet

Refer to Henbury Western location below.

Third Party Connections

Refer to Henbury Western location below.

Local Cable Routes

Refer to Henbury Western location below.

Operational Telecommunications

Refer to Henbury Western location below.

GSM-R

Refer to Henbury Western location below.

SPT Provision

Spur option only:

2x new SPT associated with the signalling into and out of the platform.

2x SPT relocated associated with signals BL1838 and BL1835

Ref:	139797
Version:	1.1
Date:	June 2015

Signalling

Refer to the Network Rail Signalling Design Group (SDG) Signalling Feasibility Report listed in Appendix H.

Environment

Whilst the site is currently at the edge of the urban area, the area to the north will be developed as part of the CPNN (Land At Wyck Beck Road And Fishpool Hill); hence, existing fields and hedgerows adjacent to the road and railway will not only be affected by the proposed station, but also by the development. Details can be found on the South Gloucestershire Council website (ref PT12/1930/O):-

<http://www.southglos.gov.uk/environment-and-planning/search-planning-applications/>

The outline planning application has been approved, subject to approval of the Section 106 agreement.

The station design and access (pedestrian, public transport and cars) should be carried out in accord with the CPNN SPD and the planning consent(s). A full Traffic and transportation assessment will be required, starting at GRIP 3 to inform the options and station design and to ensure full integration with the consents.

The site is within flood Zone 2 and the drainage design will need to be developed to take into account the station and access roads during GRIP 4.

The site lies in the Forest of Avon Policy Area.

In combination with the station and access design development at GRIP 4, a traffic impact assessment will be required to assess both the construction and operational impacts on the existing highway network and revised requirements for highways, including pedestrians and buses during operation.

The residences to the south will be sensitive to noise (e.g. the station PA) and trains during operation as well as construction impacts like dusts, noise, construction lorries etc. These impacts need to be scoped and assessed during GRIP 4. The impacts on the residents and the community of introducing new station access, platform and facilities will also require careful design and assessment to ensure the best options are chosen and significant effects mitigated during construction and for the operational station.

The requirements for utilities at the station and the proximity of existing utilities need to be taken into account during GRIP 4 to ensure they are assessed and the necessary consents and wayleaves identified.

Refer to Appendix G for Environmental Appraisal.

Electrical / Utilities

Refer to Henbury Western Location (includes Points Heating) below.

Ref:	139797
Version:	1.1
Date:	June 2015

Cycle Paths

A cycle route the NCN4 runs to the North of the proposed station on the A4018, cycle route links will be developed further as part of the wider CPNN Filton Airfield re-development.

Access Points

At this location the Spur option has the potential to provide a further RRAP access from the proposed Station car park, should this be required.

Fencing / Security

The new station would require suitable fencing and security to separate the public from the railway, this will need to be designed with consideration being given to high level of development taking place in the area and how this will impact on the risk from vandalism and crime.

The British Transport Police would be given the opportunity to advise on security, trespass and anti-vandalism measures at later stages of the GRIP process.

Structures

These proposals do not affect any of the adjacent structures.

Bridge Clearance

During detailed design topographical surveys will be carried out on the station sites. This will include the recording of clearances to the Wyck Beck Road overbridge, to the west of the proposed station platforms. This will provide the basis for designs that can accommodate relevant freight and passenger services. This gauging survey would also confirm the clearances available for overhead line electrification.

9.5 Henbury (Option 2 Western Former Station Location)

The site of the former station at Henbury at 115m 31ch - immediately to the east of Station Road overbridge and adjacent to proposed CPNN development to the north. The station configuration for a spur service would be different from that for a loop as discussed below.

Track

The potential arrangements at the former station site are shown on URS drawing No. 47072043-SW-PW-DRG-7002 included in Appendix J.

Ref:	139797
Version:	1.1
Date:	June 2015

Spur Services (Option 2A)

The track infrastructure required to support this option is a new Down to Up Branch facing crossover and a new turnout in the Up Branch line leading to a bay platform line. The new crossover is best located on an existing straight element between reverse curves which is centred around 115m 6ch.

A Cvs 13, 25 mph RH layout would provide a 25 mph crossover move at this location. There is insufficient length of straight to accommodate the turnout to the bay platform line and this turnout is best located on a full circular curve of approx. 1210m radius at 115m 19ch. A Dvs 10.75 contra-flexure RH turnout, with through line cant locally reduced from 55 to 40mm, would provide a 25 mph connection to the bay platform line. The bay platform line itself would be formed from new flat bottomed CWR on steel or concrete sleepers. The signalling arrangements are such that there is no requirement for any trapping/friction stop block protection at the exit from the bay platform onto the Up Branch line. At the termination of the bay line a friction stop block would be provided with deceleration characteristics appropriate for the speed and weight of the proposed DMU services. Although the through lines at this location fall from east to west at a gradient of approx. 1 in 264 the bay line and attendant platform would be constructed to a level gradient and a straight horizontal alignment.

The bay platform line has been located at sufficient interval from the existing Up Branch line to permit the construction of a single faced platform adjacent to the Up Branch should the initial spur operating scenario be replaced with a loop service at a later date.

The current trackform at this location comprises flat bottomed CWR with concrete sleepers on the Up Branch and steel sleepers on the Down Branch. The linespeed is 60 m.p.h. on both lines and the top and line characteristics are perfectly adequate for these speeds. In addition to the installation of the new crossover/turnout and the bay platform line, design lining should be undertaken between 115m 0c and 115m 32c to regularise the track geometry and manage the local cant reduction on the Up Branch line.

Loop Services (Option 2B)

To support loop services at the former Henbury station requires the construction of two single faced platforms adjacent to the Up and Down Branch lines. No new switch and crossing layouts are required for this operating scenario but it is recommended that the Branch lines are design lined through the proposed platform areas to regularise the track geometry and intervals.

The twin tracks at the proposed platform locations follow concentric LH circular curves (facing high mileage) of approx. 1210m radius. Inevitably the proposed platforms would follow the curvature of the track and the provision and maintenance of acceptable platform passing clearances and steeping distances would be a key element of the design proposal.

A longitudinal gradient of approx. 1 in 264, falling from east to west, applies at the site of the proposed platforms. This is considerably steeper than the recommended maximum gradient of 1-500 set out in Railway Group Standards for platform

Ref:	139797
Version:	1.1
Date:	June 2015

longitudinal gradients. There is a recognised process for the identification of risks associated with platform gradients steeper than 1 in 500 and if the loop operation scenario is identified as the preferred option then this process would be invoked. The fact that the loop service scenario would not involve units being turned back in either of the single faced platforms would somewhat de-risk this option.

As an alternative to seeking derogation from Railway Group Standards for platforms steeper than a 1 in 500 gradient consideration could be given to a revision of the track vertical profile to create a gradient of at least 1 in 500. Using the Station Road overbridge as the point of no change the track would need to be progressively lowered to the east for a distance of some 130m (5 car standage) to create a 1 in 500 gradient. A minimum lowering of approx. 300 mm would be required to achieve 1 in 500 over this extent and there would need to be a corresponding steepening of the gradient to the east to compensate for the lowering. Sub-grade modification, the need for cess lowering and track drainage would all require outline design and costing.

Should the loop operating scenario emerge as the preferred option then both the derogation route and the revised vertical profile would require detailed consideration.

The current trackform at this location comprises flat bottomed CWR with concrete sleepers on the Up Branch and steel sleepers on the Down Branch. The linespeed is 60 m.p.h. on both lines and the top and line characteristics are perfectly adequate for these speeds.

Civils

It is proposed that the new station will have platforms in the same location as the historic station, although platforms will need to be completely rebuilt. The 20 space station car park (including 3 disabled), bus stop, drop of point, cycle stands and ticketing facilities will be to the North of the railway, whereas the historic station buildings are to the South of the Railway (these buildings and surrounding land has been sold off and is now in industrial use). The vehicle access to the car park will be off Station Road, through the adjacent development site. The proposed car park layout is a concept design only as the road layout for the adjacent development is yet to be finalised.

Refer to URS drawing No. 47072043-SW-CV-DRG-0004 included in Appendix J

If option 2A (the spur service) is selected then a single new platform will be constructed with a straight and level alignment to the north of the existing historic platform location leaving an area wide enough to provide passive provision for a platform to be constructed to serve the branch line for a future loop service. The new platform will be designed for 4 car train units, 101m long plus a 25m passive provision for 5 car units. The platform will have a waiting shelter and two benches. The platform would be located to the North of the existing railway corridor and will require a third party strip of land to accommodate it.

Refer to URS drawing No. 47072043-SW-CV-DRG-0005 included in Appendix J

Ref:	139797
Version:	1.1
Date:	June 2015

If option 2B (the loop service) is selected then two new platforms will be required. The historic platform alignments (curved gradient) will be followed, but it is expected that existing platforms will require complete replacement. The new platforms will be designed for 4 cars, 101m long plus a 25m passive provision for 5 car units. Each platform will have a waiting shelter and two benches. This option will require a footbridge to link the new platforms with associated DDA compliant ramps. To the North a strip of land will need to be secured to accommodate the new platform as per the previous option, and additionally it will require a strip of land to the rear of the southern platform (currently an industrial yard/car park) to be secured in order to construct the required footbridge ramps/stairs. The footbridge would be a steel structure based on NR standard details and may require piled foundations.

The new platforms will require drainage channels to the rear edge. These channels will discharge into adjacent track drainage where present. If track drainage is not present then a suitable soak away will be provided.

The new station car park will be provided with a suitable SUDS compliant soak away, subject to geotechnical investigations. Should these investigations prove that the conditions are not suitable for a soak away then a connection to the local sewer system and the associated consents will be required

The new station would have a vehicle access with curve radii to enable the use of Bristol Rapid Transit type buses, car parking for 17 cars plus 3 disabled spaces and 18 cycle rack spaces, station footprint forms part of the developers planning application and includes the provision of a food store to the eastern boundary of the car park and an electrical sub-station.

Telecoms (All options)

Station Information & Surveillance Systems (SISS)

The most efficient method of providing modern Station Information & Surveillance Systems (SISS) for small stations is to provide an IP (internet protocol) based solution. This allows all systems to be connected to a common station switch which uses a single connection to the outside world. All systems are housed in a single, centrally positioned, equipment cabinet and powered from a single 230 volt DNO supply supported by an Uninterruptable Power Supply (UPS) to provide a 1-hour back up for the CCTV system. The generic diagram below gives a typical system schematic for a small station scenario.

Ref:	139797
Version:	1.1
Date:	June 2015

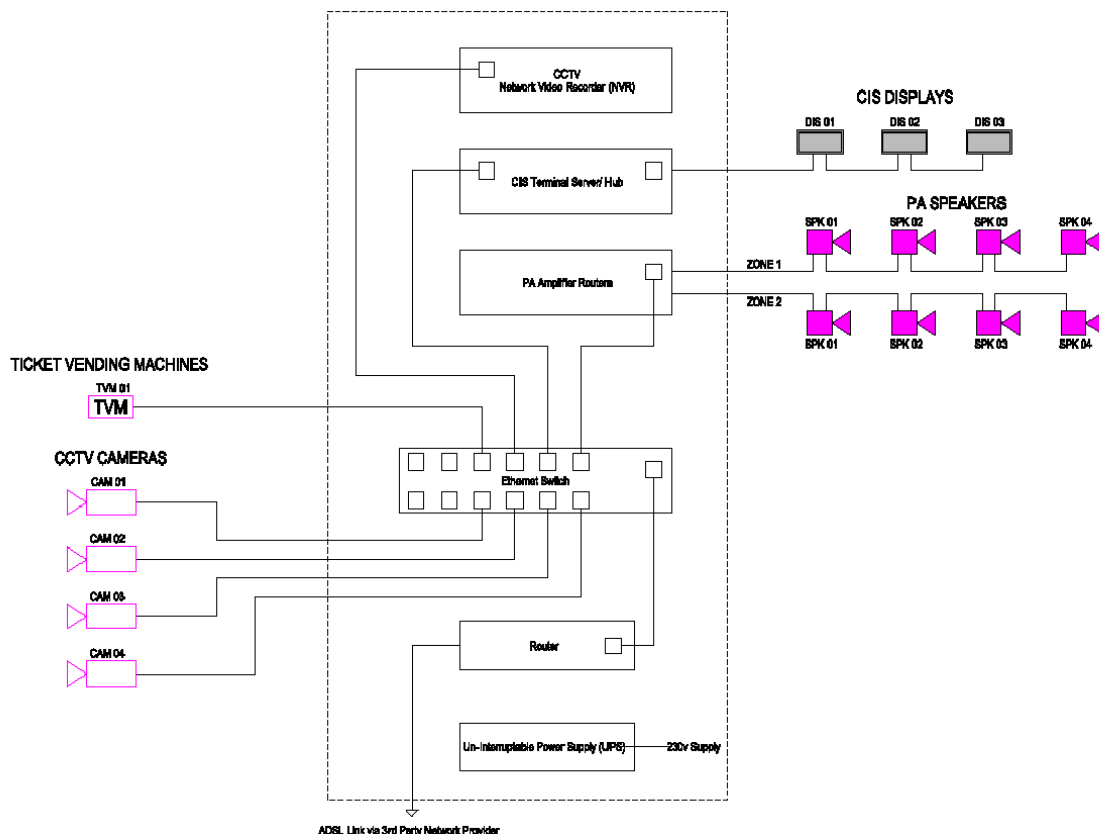

Operational Telecommunications

For small stations, the extent of operational telecommunications will be limited to the provision of Telephones associated with the signalling systems and the management of the lineside cable route.

Closed Circuit Television (CCTV)

Any system provided at Henbury Station, shall be compliant with Network Rail Standard NR/L2/TEL/30135 and developed as previously stated with the TOC, BTP and other interested parties.

The system shall be designed for general monitoring of the stations, particularly entrances / exits and will offer a means of enhancing the safety and security of the public, staff and the general management of the station.

The system shall make provision to include 24 hour surveillance of the station car parking facilities. The cameras shall be suitable for both day and night operation, maintaining a good quality level of coverage, even when the light levels diminish.

CCTV images shall be recorded locally on a NVR. The system shall be designed to enable monitoring and recovery of recorded images from a remote location.

The use of IP cameras is recommended. These cameras can be operated and powered directly from the station Ethernet Switch via CAT6 cables up to a maximum distance of 90 metres. This will require the equipment cabinet to be located centrally

Ref:	139797
Version:	1.1
Date:	June 2015

for maximum flexibility. Cameras beyond 90 metres can be fed using CAT6 line extenders. An Ethernet Switch, capable of providing Power over Ethernet (PoE), must be used to satisfy the above. The following camera quantities for each option are recommended to meet the current Network Rail Specification:-

- 2a. 17
- 2b. 30

Public Address (PA)

A PA system is recommended to broadcast secure, high intelligibility speech to all public areas on station platforms; this may include pedestrian access areas to the platforms if required. The requirements for the new PA system shall be compliant with Network Rail Standard NR/L2/TEL/30134 and as agreed with the TOC. It is recommended that an acoustic survey and modelling of the PA catchment areas be undertaken, to ensure that environmental noise is kept to a minimum and therefore reduce the impact on the neighbouring residents. The following speaker quantities for each option are recommended to meet the current Network Rail Specification.

- 2a. 8
- 2b. 20

In order to instigate and update the announcements and for fault reporting, a link from the local PA control equipment at the station, to the associated TOC Control Centre will be achieved via the Station Ethernet switch.

To aid passengers with hearing difficulties, the PA system must include an integrated Induction Loop facility.

Customer Information Systems (CIS)

A Customer Information System is recommended, delivering live train information to the travelling public both for passengers in transit from the station car park and those waiting on the station platforms.

The requirements for the new CIS system shall be compliant with Network Rail Standard NR/L2/TEL/30130 and as agreed with the TOC. The following display quantities for each option are recommended to meet the current Network Rail Specification.

- 2a. 2
- 2b. 5

In order to instigate and update the train information displayed, a link from the local CIS control equipment at the station, to the associated TOC Control Centre will be achieved via the Station Ethernet switch

Ref:	139797
Version:	1.1
Date:	June 2015

Passenger Help Points (PHP)

It is proposed that the PHPs installed at Henbury Station be GSM (mobile) enabled, allowing installation and operation regardless of the availability of local rail telecommunications infrastructure. This can also be achieved via a more traditional leased line from a third party provider. This decision will be in consultation with the TOC

PHPs shall be a two button type unit with one button marked 'Information', the second 'Emergency'. Calls are routed via the GSM provider or, in the case of a leased line, the Public Switched Telephone Network (PSTN) to the information call centre. A quantity of 1 PHP per platform for each option is recommended.

To aid passengers with hearing difficulties, the PHP shall include an Induction Loop facility, integrated within the passenger help point enclosure.

Ticket Vending Machine

Two Ticket Vending Machines will be provided. Each ticket machine works independently but uses a telecommunications data link to upload sales information and transactions to its main control. This data link is provided from the main station switch housed in the telecommunications equipment cabinet.

Telecommunication Equipment Cabinet

An equipment cabinet, designed for external use, is recommended to house the Power, Ethernet Switch & Router, CCTV, PA and CIS control equipment. This will need to be located in a high street environment and in a central position that provides unhindered access for maintenance purposes. A standard mains 230 volt supply will need to be provided.

Given the amount of sensitive equipment installed it is recommended that a cabinet with thermal management and EMC protection is provided to prevent any issue associated with extreme temperature excursions and electrical interference.

Third Party Connections

A third party Asynchronous Digital Subscriber Line (ADSL) connection will also be required at Henbury Station.

This third party connection will allow the Station Ethernet switch to be connected, via the station router, to the TOC control centre in order to provide updated information for all SISS systems.

Local Cable Routes

All the SISS systems mentioned above will require a local cable route from the equipment to the centralised equipment cabinet. A platform duct route is

Ref:	139797
Version:	1.1
Date:	June 2015

recommended with a centrally located under track crossing (UTX) for access to the other platform, (not required for the Henbury single platform option).

Operational Telecommunications

Lineside Telephony:

It is assumed that there are to be starting signals on the ends of station platforms; therefore there may be a requirement for Signal Post Telephones (SPTs) associated with each signal. The position of the telephone will be determined by the signal sighting committee.

The existing line side cable infrastructure shall be used to connect the operational telephones to the controlling Signal Box. This will require a full survey to determine the capacity and condition of the existing cable infrastructure and the location of suitable terminations and connection points. Should the existing Infrastructure prove not fit for purpose, then other options must be considered for operational connectivity, these may include;

1. Provide new line-side cable infrastructure,
2. Remodelling of existing cable infrastructure,
3. Leasing 3rd party circuits,
4. Provision of IP operational telephones via the Station Ethernet Switch (subject to Network Rail approval).

A similar survey must be undertaken to establish the condition and capacity of the telephone concentrator at the controlling Signal box. If sufficient capacity exists then this can be used for any additional operational telephones. Should there be insufficient capacity, then an upgrade or replacement of the telephone concentrator must be considered.

Existing Lineside Cable Route:

The building of new stations, or the rebuilding of old, will impact on the position of the line-side cable route. A survey will be required to establish the exact position of the line-side cable route with respect to the new station construction (all options). It is important that where such cable routes exist, that these are diverted and/or fully protected during the station construction phase.

During the station design phase, provision must be made for a fully re-instated, fit-for-purpose cable route that affords unhindered access to the installer and maintainer alike.

Ref:	139797
Version:	1.1
Date:	June 2015

GSM-R

From current data, there is no GSM-R infrastructure that would be affected by any proposed works. There will however be a requirement to update the GSM-R database as a result of this project.

SPT Provision

Spur option only:

2x new SPT associated with the signalling into and out of the platform.

2x SPT relocated associated with signals BL1838 and BL1835

Signalling

Refer to the Network Rail Signalling Design Group (SDG) Signalling Feasibility Report listed in Appendix H.

Environment

Whilst the site is currently at the edge of the urban area, the area to the north will be developed as part of the CPNN (Land At Cribbs Causeway); hence, existing fields and hedgerows adjacent to the road and railway will not only be affected by the proposed station, but also by development as part of the CPNN. Details can be found on the South Gloucestershire Council website (ref PT14/0565/O):-

<http://www.southglos.gov.uk/environment-and-planning/search-planning-applications/>

The outline planning application for the site has been submitted to South Gloucestershire Council for determination in 2015.

The site is in the Forest of Avon policy area, and in Flood Zone 3. A flood risk assessment and drainage design will be required during GRIP 4.

There is a residence that will be affected (Woodside house) immediately to the west of the station. There are also residences to the south of the track off Tormarton Crescent which although south of the concrete works on the old station yard may be sensitive to noise (e.g. the station PA) and trains during operation as well as construction impacts like dusts, noise, construction lorries etc.

The B4055 crosses the railway on a bridge with limited visibility; pedestrian access on the B4055 is limited to the western side of the road. A traffic impact assessment will be required to assess both the construction and operational impacts on the existing highway network and revised requirements for highways, including pedestrians and buses during operation.

The requirements for utilities at the station and the proximity of existing utilities need to be taken into account during GRIP 4 to ensure they are assessed and the necessary consents identified.

Refer to Appendix G for Environmental Appraisal.

Ref:	139797
Version:	1.1
Date:	June 2015

Electrical / Utilities

Option 2A (Spur):

It is proposed that a new DNO supply will be installed. The DNO cubicle will be positioned in close proximity to the station adjacent to a fenced area which is easily accessible. The DNO cubicle will be double sided. One side would consist of DNO equipment and a meter, accessed on the public side of the fence thus allowing for straight forward meter reading and necessary maintenance. The second railway side of the cubicle would contain the distribution and lighting control systems and would be easily accessible by rail staff. A pedestrian gate adjacent to the DNO cubicle might be necessary.

The lighting of the platform would need to comply with Railway Group Standards GI/RT/7016 and RIS-7702-INS and therefore should achieve a maintained horizontal minimum of 20Lux with a minimum uniformity of 0.4. This is consistent with driver only operated (DOO) stations. The vertical illuminance at a height of 1m to the platform surface at the edge of the platform will need to be 6Lux for DOO stations. However, the RIS standard mentions that lighting should be developed to any task that might be undertaken on the platform and if there are any tasks that require a certain level of detail to be completed the Lux levels will need to be revised relevant to that task.

In order to comply with the DDA, the lighting of the station needs to be taken into consideration. Therefore for the platform ramp/stairs the lighting level should achieve a minimum of 100lux and the DfT Code of practice does not give minimum Lux levels or uniformity so this would be in line with the 0.4 requirement of RIS-7702-INS. Usually DDA requirements are not applied to platform areas with the group standard values being adopted. For a ticket counter or ticket machine a minimum of 300Lux with a uniformity of 0.5 will be required.

The luminaries for the platform are shown to be 5m above the platform and are at 10m spacing's. This is based on the guidance applied by the manufacturers that set out the maximum distance between luminaires is twice the height of the column. From past experience it should be possible to attain the required illuminance levels. The heights and spacing's for the proposed luminaires will be confirmed at the GRIP 3 stage of the project by calculation either by hand or by an employer approved calculation package. The use of raise and lower columns mean that the maintenance staff can carry out maintenance and repair at platform level. It is proposed that the raise and lower jack be kept in the vicinity of the station where it can be safely stored.

The waiting shelter is assumed to be a transparent or translucent type structure that will not require separate lighting requirements and the platform lighting will provide enough lighting for its use. However this is to be confirmed during the GRIP 3 stage of the project and if an opaque shelter is to be used then the lighting inside the shelter shall be to, as a minimum, the same level as the platform and the control of the lighting will be tied into the platform lighting control system.

The supplies for the telecoms equipment such as Customer Information System (CIS), Close Circuit Television and Public Announcement will be feed from the station distribution board located in the confines of the DNO (distribution side) cubicle.

Ref:	139797
Version:	1.1
Date:	June 2015

It has been assumed that a gas and water supply is not required for the station.

Car parks will need to be lit in accordance with BS 5489-1 and be a minimum of 5Lux with a uniformity of 0.25. However the DfT Code of practice does not give any guidance on car parking areas for DDA requirements, however if DDA requirements are to be applied in the car park then it is recommended that a minimum of 100Lux with a uniformity of 0.25 be applied

For indicative purposes only, 5m columns with luminaires have been shown with a typical 10m spacing. Double headed lighting columns have been used where necessary and flat glass luminaires are proposed to reduce glare and light pollution. Where car park lighting columns are in vulnerable positions collision protection would be provided.

Option 2B (Loop):

It is proposed that a new DNO supply will be installed. The DNO cubicle will be positioned in close proximity to the station adjacent to a fenced area which is easily accessible. The DNO cubicle will be double sided. One side would consist of DNO equipment and a meter, accessed on the public side of the fence thus allowing for straight forward meter reading and necessary maintenance. The second railway side of the cubicle would contain the distribution and lighting control systems and would be easily accessible by rail staff. A pedestrian gate adjacent to the DNO cubicle might be necessary.

The lighting of the platform would need to comply with Railway Group Standards GI/RT/7016 and RIS-7702-INS and therefore should achieve a maintained horizontal minimum of 20Lux with a minimum uniformity of 0.4. This is consistent with driver only operated (DOO) stations. The vertical illuminance at a height of 1m to the platform surface at the edge of the platform will need to be 6Lux for DOO stations. However, the RIS standard mentions that lighting should be developed to any task that might be undertaken on the platform and if there are any tasks that require a certain level of detail to be completed the Lux levels will need to be revised relevant to that task.

In order to comply with the DDA, the lighting of the station needs to be taken into consideration. Therefore for the platform ramp/stairs the lighting level should achieve a minimum of 100lux and the DfT Code of practice does not give minimum Lux levels or uniformity so this would be in line with the 0.4 requirement of RIS-7702-INS. Usually DDA requirements are not applied to platform areas with the group standard values being adopted. For a ticket counter or ticket machine a minimum of 300Lux with a uniformity of 0.5 will be required.

The luminaries for the platform are shown to be 5m above the platform and are at 10m spacing's. This is based on the guidance applied by the manufacturers that set out the maximum distance between luminaires is twice the height of the column. From past experience it should be possible to attain the required illuminance levels. The heights and spacing's for the proposed luminaires will be confirmed at the GRIP 3 stage of the project by calculation either by hand or by an employer approved calculation package. The use of raise and lower columns mean that the maintenance staff can carry out

Ref:	139797
Version:	1.1
Date:	June 2015

maintenance and repair at platform level. It is proposed that the raise and lower jack be kept in the vicinity of the station where it can be safely stored.

The waiting shelter is assumed to be a transparent or translucent type structure that will not require separate lighting requirements and the platform lighting will provide enough lighting for its use. However this is to be confirmed during the GRIP 3 stage of the project and if an opaque shelter is to be used then the lighting inside the shelter shall be to, as a minimum, the same level as the platform and the control of the lighting will be tied into the platform lighting control system.

The supplies for the telecoms equipment such as Customer Information System (CIS), Close Circuit Television and Public Announcement will be feed from the station distribution board located in the confines of the DNO (distribution side) cubicle.

The overbridge steps and access ramps will be designed to BS 5489 and be 30Lux with a uniformity of 0.5. In order to comply with the Disable Discrimination Act (DDA, which has since evolved into the Equalities Act 2010). there is a requirement for a minimum of 100Lux from the entrance to the overbridge to the platform. This is taken from the Department for Transport Accessible Train Station Design for Disabled People: A Code of Practice. There is no uniformity given in the DfT Accessible Train Station document but it is recommended that the uniformity of 0.5 be applied according to the BS 5489 standard.

The lighting of the overbridge has been shown to be achieved with the lighting columns of the station platforms. However additional lighting may be required depending on the side wall construction of the ramps and steps to overcome shadow effects. A light, central to the cross track walkway, has been shown to aid the lighting levels in the area. The bridge will need to include a suitable cable route to connect any additional lights that may be needed. These additional lights could be installed on frames above the bridge deck, or alternatively form part of the overbridge construction and be positioned in recessed areas to provide necessary lighting.

It has been assumed that a gas and water supply is not required for the station.

Car parks will need to be lit in accordance with BS 5489-1 and be a minimum of 5Lux with a uniformity of 0.25. However the DfT Code of practice does not give any guidance on car parking areas for DDA requirements, however if DDA requirements are to be applied in the car park then it is recommended that a minimum of 100Lux with a uniformity of 0.25 be applied.

For indicative purposes only, 5m columns with luminaires have been shown with a typical 10m spacing. Double headed lighting columns have been used where necessary and flat glass luminaires are proposed to reduce glare and light pollution. Where car park lighting columns are in vulnerable positions collision protection would be provided.

Ref:	139797
Version:	1.1
Date:	June 2015

Points Heating and Signalling Power Supplies (This applies to the Spur Options 1A & 2A)

The following is based on the Draft Signalling Scheme Sketch SDG/SSK/139797?GS2/5 version 0.02, as well as the P-Way drawings 47072043-SW-PW-DRG-7000 to 7003.

There are several proposals for Henbury and for Option 1B and Option 2B there are no additional points to be added to the scheme in this area. However for Options 1A and 2A (East Site) there is a proposal to add three new points for which a three phase control cubicle and three phase supply will be necessary. The points heating is to be investigated at GRIP 3 stage of the project and confirmed if 100W/m, 150W/m or 200W/m strip heaters are to be utilised. Due to the extra points being added it increases the signalling power supply load by 5400VA and a small load associated with the controlling signals (approx. 100VA) will also be added as part of the proposal.

For option 1A four new signals will be added and three are being recovered, assuming that the load of a light signal is 40VA then the overall load increase will be 40VA. For option 2A three new signals will be added and two are being removed therefore the overall load increase is approx. 40VA.

For signalling power supplies the Avonmouth PSP would need to be investigated to determine if there is spare capacity to support the additional loads at Henbury. The increase in signalling power loads should be able to be accommodated in the local signalling power supply network since the additional load is anticipated to be below the typically 20% spare capacity allowed for in the signalling supply for future additions. Alternatively the signalling power supplies can be derived from the DNO supply associated with the points heating installation and at the DNO distribution cubicle one switch would be used to supply the points heating and another will be used to supply a local principal supply point suitable for the proposals. If this option is taken forward the use of a static generator and UPS will need to be confirmed during the GRIP 3 stage of the project.

For option 1A and 2A there is a proposal for buffer stop lighting and it is anticipated that this will be supplied via the General Distribution Board of the points heating control cubicle or station supply utilised to provide a power supply to the buffer stop.

It should be investigated if the Bristol Area Signalling Relock and Recontrol (BASRE) project, currently under development, could be utilised to incorporate the additional point loads. The existing signalling power supplies in the area should have a 20% spare capacity for additional future loads and the signalling power supplies in the area should be able to accommodate this small load.

Cycle Paths

A cycle route the NCN4 runs to the North of the proposed station on the A4018, cycle route links will need to be designed in accord with the wider CPNN development proposals.

Ref:	139797
Version:	1.1
Date:	June 2015

Access Points

There is an existing Network Rail track access to the south and west of the historic station; these proposals will not affect this.

The Spur option has the potential to provide a further RRAP access from the proposed Station car park.

Fencing / Security

The new station would require suitable fencing and security to separate the public from the railway. This will need to be designed with consideration being given to the high level of development taking place in the area and how this will impact on the risk from vandalism and crime.

The British Transport Police would be given the opportunity to advise on security, trespass and anti-vandalism measures at later stages of the GRIP process.

Structures

These proposals do not affect any of the adjacent structures.

Bridge Clearances

During detailed design topographical surveys will be carried out on the station sites. This will include the recording of clearance to the Station Road overbridge, to the west of the proposed station platforms. This will provide the basis for designs that can accommodate relevant freight and passenger services. This gauging survey would also confirm the clearances available for overhead line electrification.

9.6 Yate

Track

The preferred arrangements for a potential new turnback siding to the north of Yate station are shown on URS drawing No. 47072043-SW-PW-DRG-7005 included in Appendix J.

It is proposed to provide a new turnback siding to the Downside of the existing twin tracks to the north of Yate station. The siding would be of sufficient length to accommodate 4 car units and passive provision for extension to 5 car units would be available. The switch toes of the new turnout would be at 119m 44ch on the Down Charfield line of the BGL2 route. The location of these toes is approx. 190m north of the existing Downside (No. 1) platform at Yate. This distance will allow existing signalling equipment, which facilitates freight operations at the site, to be retained.

Ref:	139797
Version:	1.1
Date:	June 2015

The main lines at the site of the proposed turnout follow concentric RH curves (facing high mileage) of approx. 5500m radius with 30mm of installed cant. A Dvs 15 contra-flexure turnout would permit a 25 mph move to and from the turnback siding. The turnback siding itself would be formed from flat bottomed CWR on concrete or steel sleepers laid to a 1 in 500 gradient falling towards the stop block end. A trap point, comprising a set of Bv switches and a lead rail, will be required to protect the Down Charfield line from unauthorised moves from the turnback siding. A fixed stop block would be installed at the termination of the siding.

The condition of the existing plain line of the Down Charfield at the site of the proposed turnout is good, being FB113A CWR on concrete sleepers

The arrangements shown on the above drawing provide the most cost effective and flexible solution of all the options discussed under section 6.2 for the following reasons:-

- 1 – They permit long duration turnarounds to be accommodated in a proposed new turnback siding.
- 2 – They centre all down passenger services on the Down Charfield (No.2) platform, which replicates the current situation.
- 3 – They avoid the cost of a new crossover with attendant signalling between the Up & Down Charfield lines.

Civils

The existing station at Yate consists of a staggered “Up” and “Down” platform arrangement either side of the A432 (Station road) in Yate. The proposals for the new turnback siding do not require alterations to the existing platform infrastructure.

A new driver’s walkway will be required adjacent to the proposed turnback siding to the North of the station. This will be constructed to NR standard details and will require lighting.

Telecoms

The diagram below gives the approx. layout of the existing infrastructure.

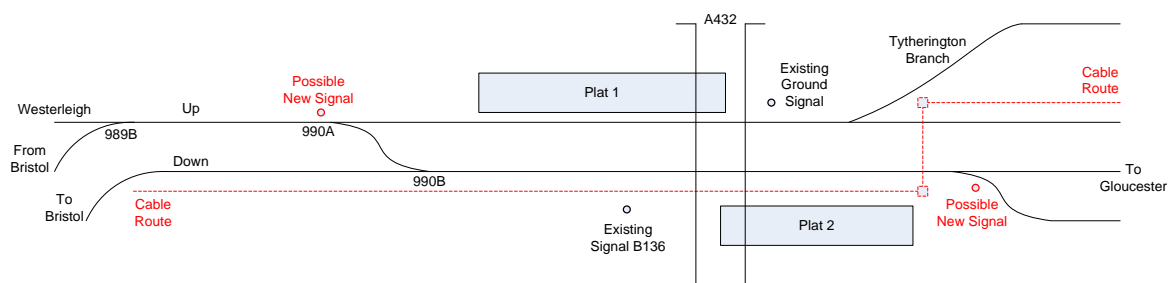

Ref:	139797
Version:	1.1
Date:	June 2015

Existing Station Information & Surveillance Systems (SISS)

Currently this station has CCTV cameras and help points. It is not envisaged that the station information and surveillance systems are upgraded under this scheme.

Existing Operational Telecommunications

Platform 1 (Up Charfield):

There is a ground signal approx. 5 metres off the East Platform end that affords operational access to the Tytherington branch. This has no operational telephone associated with it.

Platform 2 (Down Charfield):

There is an existing signal (B136) at the West end of platform 2. This is used as a starting signal for trains at platform 2 and to signal trains across points 990 into Westerleigh, This may have an operational telephone associated with it, a survey will be required to confirm this.

Cable Routes:

Reference should be made to the diagram of the station above. The Main line side cable route is in the down cess on the Bristol side of the station and goes though Platform 2 to a position approx. 20 metres beyond the Gloucester end of the Platform. At this point it crosses, via an under track crossing (UTX), to the up cess where it continues on the Charfield line towards Gloucester.

New Operational Telecommunications Requirements

Alteration to the operational telecoms infrastructure may be required. This is dependent on the signalling requirements developed for this project.

It is possible that any new signals will require Signal Post Telephones. This will require the following survey/investigation work to enable design options to be produced:

1. Availability of line side copper cable Infrastructure including termination and connection points.
2. The spare capacity on the controlling signal box telephone concentrator.

SPT Provision

1x new SPT associated with signal BL2034

1x new SPT associated with the turnout

Ref:	139797
Version:	1.1
Date:	June 2015

Signalling

Refer to the Network Rail Signalling Design Group (SDG) Signalling Feasibility Report listed in Appendix H.

Environment

There are mature trees on both sides of the alignment; their removal to make way for the new turnback facility will have an effect on the views from houses and the industrial units.

The houses in Plover Crescent will be sensitive to noise, dust and the loss of the mature trees along their boundary, during construction. Nesting birds may be present in the trees and an ecology survey will be required to identify all protected species prior to commencement of construction. The new operating regime will increase the level of noise due to trains idling in the turnback siding close to residents in Plover Crescent. The effects of this and any mitigation that may be required may need to be considered in later design phases.

A review of construction strategy, access etc. and drainage design will be required at GRIP 3.

Refer to Appendix G for Environmental Appraisal.

Electrical / Utilities

There are no alterations proposed to the existing station infrastructure at Yate with only a new turnback facility being proposed. This will affect Points Heating and Signalling Power Supplies and this has been highlighted in the points heating and signalling section below.

Points Heating and Signalling Power Supplies

The following is based on the Draft Signalling Scheme Sketch, as well as the P-Way drawings 47072043-SW-PW-DRG-7000 to 7003.

The proposed enhancement would see the creation of a turnback siding. This would mean that a new section of track to form the turnback facility will be added. This subsequently means a new buffer stop light would have to be installed.

The points heating is to be investigated at GRIP 3 stage of the project and confirmed if 100W/m, 150W/m or 200W/m strip heaters are to be utilised. The points heating control cubicle is a single phase cubicle that currently provides heating for Points 922A and 922B and the DNO is rated at 100A. To comply with current standards the DNO supply will need to be upgraded from a single phase supply to a three phase supply, and a new points heating control cubicle installed in place of the existing control cubicle.

The new point will add approx. 1800VA to the signalling power supply requirements in the area. It is anticipated that this increase in load will be accommodated by the

Ref:	139797
Version:	1.1
Date:	June 2015

existing signalling supply system since this should have spare capacity to accommodate a small increase in load.

The buffer stop light power supply will be via a spare way in the General Distribution Board of the points heating control cubicle. A step down transformer will be installed and used to step down the voltage from 230 volts to the required 110 volts suitable for signalling supplies.

A new cress walkway is proposed to provide a safe path for the driver to get off the train and board the train at the other end safely. This cress path will be lit at an average of 20lux and will need a uniformity of 0.4. It is anticipated that the walkway will be lit using bollard lighting and will be typically placed at 5m intervals along the cress walkway.

Cycle Paths

As existing arrangements.

Access Points

As existing arrangements.

Fencing / Security

As existing arrangements.

Structures

As existing arrangements.

Bridge Clearance

There is no impact on the clearances to the existing Station Road overbridge between the staggered platforms at Yate Station.

9.7 Hallen Marsh Junction (including Holesmouth Junction)

Track

The preferred arrangements for the remodelling of Hallen Marsh Junction, to permit additional passenger routings across the junction to and from the Severn Beach single line, are shown on URS drawing No. 47072043-SW-PW-DRG-7004, included in Appendix J. It should be noted that the remodelling of Hallen Marsh Junction is only required if the loop service pattern is adopted and it can remain as currently configured for the spur service.

Ref:	139797
Version:	1.1
Date:	June 2015

The loop operating scenario places additional routings of passenger services over Hallen Marsh Jn. The capability of this junction is restricted by the need for reverse line running for both Down Avonmouth and Up Bennets Siding (Bristol Port Company) services from Hallen Moor East Jn. Given the increased service level of the loop service it is recommended that Hallen Marsh Jn. is remodelled to remove constraints and enhance flexibility. The installation of two additional crossovers, one from the Severn Beach single to the Bristol Bulk Handling Terminal (BBHT) Departure Road and one from the BBHT Departure Road to the BBHT Arrival Road, offers a good solution to the removal of the constraints. In addition to the two new crossovers discussed above it is proposed to relocate the turnout from the Severn Beach Single line to Bennets Siding some 150mtrs to the north. This move locates the turnout to the north of the crossover between the Severn Beach Single line and the BBHT Departure Road thus significantly enhancing the parallel moves available at the junction.

The signalling and trackwork costs associated with the above remodelling are high and consideration was given to a cheaper option which required just one additional crossover. This additional crossover would be located north of the existing signal gantry at the site and permit moves between the BBHT Arrival & Departure lines. The Network Rail Operational Modelling team reviewed this single crossover arrangement but concluded that the remaining constraints were too severe to robustly support the additional services across the junction. It was therefore agreed that the new twin crossover arrangement with attendant turnout relocation was the option to be taken forward.

An initial twin crossover option which located the crossovers further to the south and involved the considerable cost of relocating a major signalling gantry has been superseded by the current proposal which allows the gantry to remain in its existing position.

It is not possible, at reasonable cost, to locate the proposed two new crossovers on straight track as would be preferred. Accordingly it is proposed to locate them on concentric curved alignments of approx. 1100m radius with installed cants of 25mm. The southern legs of both of the proposed crossovers would lie close to or beneath the overbridge which is an undesirable feature of the design from a track perspective. Both of the proposed layouts would comprise DVs 15 transitioned crossovers and the cant/curvature relationship of the design would permit 30 mph crossover moves between adjacent tracks.

The track condition of the existing plain line and switch and crossing layouts at the junction is good but design lining would be required between 14m 40ch and 14m 55ch (AMB route) to regularise the track geometry and permit the installation of standard switch and crossing layouts.

Opportunity would be taken to rationalise some redundant track, signalling and E&P assets at the junction site which formerly served the Merebank private sidings (Pasminco). The key stakeholders in the project would need to establish how the costs of any removal of redundant assets would be apportioned.

Ref:	139797
Version:	1.1
Date:	June 2015

Civils

Proposed relocated signal SA38 will require the addition of 1 new Signal base.

Telecoms

This junction is planned to be remodelled, subject to the loop service option being chosen. The remodelling will result in a net increase in 3 running line point ends and 4 new trap points. Limited alteration to the operational telecoms infrastructure will be required as follows.

- A new Signal Post Telephone (SPT) will be required for SAZZ
- Relocated signal SA38 will require a relocated SPT
- With the significant increase in point ends a new Points Zone Telephones (PTZs) will be required

The following survey/investigation work will need to be undertaken, to enable operational telecommunications design options to be produced:

1. Availability of line side copper cable Infrastructure including termination and connection points.
2. The spare capacity on the controlling signal box telephone concentrator.

SPT Provision

2x new SPT's are anticipated

2x relocated SPT are anticipated

1x new Points Zone Telephone (PZT) is anticipated for this complex junction.

Signalling

Refer to the Network Rail Signalling Design Group (SDG) Signalling Feasibility Report listed in Appendix H.

Environment

An ecological survey will be required and there is vegetation that will need to be cleared for access, equipment installation and operation of the route. This area of the Severn Estuary is sensitive and details of conservation and ecological designations can be found in the following document:-

- <http://www.severnestuary.net/sep/pdfs/sephabitatsandspecies.pdf>

However it is not anticipated that these works will have significant effects on the designations of the Severn Estuary.

Given the nature of land use in the area and the historic railway environment there may be contamination of the ground and ground water.

Ref:	139797
Version:	1.1
Date:	June 2015

Consideration should be given to the risk of flooding in the MetroWest EIA. The site is in Flood Zone 2/3, See Environment Agency flood map below (Section 7).

It is assumed the works will be consented and carried out under NWR permitted development.

The contractor will be required to produce a Waste Management Plan (WMP) for Network Rail approval. The WMP should consider as a minimum, the recovery of the existing ballast, spoil, and recovered track and all other mechanical and electrical components.

There are no residences in this area.

Refer to Appendix G for Environmental Appraisal.

Electrical / Utilities (Hallen Marsh-including Holesmouth Junction)

The following is based on the Draft Signalling Scheme Sketch ref SDG/SSK/139797/GS4/3H, as well as the P-Way drawings 47072043-SW-PW-DRG-7004.

Points Heating and Signalling Power Supplies

Currently the junction is heated using a three phase DNO supply and three phase control cubicle. The control cubicle provides heating for Points 139A, 139B, 140, 141A, 141B, 142 and 143.

The remodelled junction layout to permit passenger services on the AFR route will result in a net increase of 7 point ends including 4 new trap points to protect passenger routes across the junction. Attendant with the junction modelling 2 new fixed signals (SA38 & SAZZ) are required together with modifications to Signal SA47 and SA32.

This means there is a net gain in signalling power load and spare capacity (normally available) will need to be checked in the feeder and in the Principal Supply Point to provide power for the proposals.

Four points 137A, 137B, 138A and 138B are currently heated. The DNO for these points at site is a single phase installation and so is the control cubicle. To accommodate the additional points the DNO will need to be upgraded to a three phase supply and the control cubicle will need to be replaced with a three phase cubicle. The existing points heating are to be re-fed from the proposed control cubicle.

In terms of signalling power supplies, there is a net increase of 5 new point ends in the remodelled layout. This increases the load required for the signalling power requirements. Currently the signalling power is thought to be derived at St Andrews Road level crossing or Avonmouth PSP and this would need to be checked for spare capacity to accommodate the additional loads. The signalling load increase when comparing the new and removed point motors for the feeder increases by 9000VA assuming a single point machine has a worst case load of 1800VA.

It should be investigated if the Bristol Area Signalling Relock and Recontrol (BASRE) project, currently under development, could be utilised to incorporate the additional

Ref:	139797
Version:	1.1
Date:	June 2015

point load. The existing signalling power supplies in the area should have a 20% spare capacity for additional future loads and if load is removed, as part of the BASRE project, this should have capacity to accommodate the additional load.

Cycle Paths

N/A

Access Points

There is an existing access point to the upside at 14 miles 36 ch, will be retained.

Fencing / Security

As existing arrangements

Structures

As existing arrangements.

Bridge Clearance

During detailed design topographical surveys will be carried out on the station sites This will include the recording of clearances to the private road crossing all tracks at 14miles 49ch. This will provide the basis for designs that can accommodate relevant freight and passenger services. This gauging survey would also confirm the clearances available for overhead line electrification.

Ref:	139797
Version:	1.1
Date:	June 2015

10. Constructability and Access Strategy

10.1 Constructability

Introduction

The project is a series of separate sites that will not necessarily be interdependent from a construction point of view however the North Filton and two Henbury sites are dependent on the third party developers completing associated infrastructure such as access roads and services prior to the commencement of the station construction, alternatively temporary haul roads and temporary services could be provided to enable construction to commence however the access road and services would need to be installed prior to commissioning.

Whilst the various elements of the project are not interdependent from a construction perspective they will all need to be completed in order for the new passenger service to be inaugurated.

It is not envisaged that there will be unusual or non-standard construction methods or materials used and it would be expected that the individual elements of the project can be progressed through outline and detailed design to an 'Approved for Construction' design in a relatively straightforward way.

North Filton

Prior to the start of construction works there would need to be significant vegetation clearance of the proposed construction area, primarily of the railway embankments to allow for the completion of a detailed topographical survey, this may well form part of the outline/detailed design phases. A structural inspection and assessment of the existing platform will also need to be carried out as part of the outline design process.

Works to the platform walls and copers/tactile paving will need to be carried out during possessions as will the lifting in of the footbridge superstructure. The bridge foundations car park and platform infrastructure will be constructed in green zone working.

Currently it is not envisaged that there will be any track works at this site.

Henbury Option 1 - East

The construction methodology and sequencing for the potential Henbury East site would mirror that for Henbury West below.

Henbury Option 2 - West

Prior to the start of construction works there would need to be significant vegetation clearance of the proposed construction area, primarily of the railway embankments to allow for the completion of a detailed topographical survey, this may well form part of the outline/detailed design phases.

Ref:	139797
Version:	1.1
Date:	June 2015

For the loop option Construction of the new platforms front walls and copers/tactile paving will need to be carried out during possessions as will the lifting in of the footbridge superstructure. The bridge foundations car park and platform infrastructure will be constructed in green zone working.

For the spur option the vast majority of the work to platforms and car park can be carried out in green zone working.

From a track perspective, the loop option will merely require the survey and design of horizontal and vertical alignments on both existing tracks between 115m 20ch and 115m 40ch. This alignment design will permit the regularisation of the track geometry, intervals and crossfalls to provide an acceptable and rationalised base-line against which to construct the proposed two platforms.

The spur option involves the installation of a new crossover and turnout, the design lining of the Up branch line between 114m 75ch and 115m 40ch and the installation 200m of new plain line with attendant friction stop block to form the new bay line. It is anticipated that the new switch and crossing layouts will comprise arrangements based on Network Rail's suite of CEN 56E1 standard layouts formed on concrete bearers. The layouts themselves could be fabricated and delivered in modular form. The plain line would comprise new CEN 56E1 CWR on new concrete sleepers. A trackbed "investigations and recommendations" report would inform the nature of the trackbed to be installed to support the bay line across hitherto unloaded ground.

The installation of the new switch and crossing layouts and the design lining of the Up Branch line would require to be undertaken within possessions. The installation of the bay line could be undertaken in a fenced green zone with traffic running on the adjacent Up and Down Branch lines.

Yate

The preferred enhancements at Yate do not require any significant alterations to the platform infrastructure at the station and the civil engineering works are limited to the provision of bases for new signalling and M&E equipment and any provision of improved fencing adjacent to the proposed turnback siding. The turnback siding will require a right hand turnout and attendant trap point to be installed within possessions of the Down Charfield line. It is anticipated that the new switch and crossing layouts will comprise arrangements based on Network Rail's suite of CEN 56E1 standard layouts formed on concrete bearers. The layouts themselves could be fabricated and delivered in modular form. It is intended that the designed interval between the turnback siding and the adjacent Down Charfield line will permit the installation of the trackbed and plain line/friction stop block largely within a fenced green zone. The plain line would comprise new CEN 56E1 CWR on new concrete sleepers. A cess path, compliant with relevant construction standards, would be provided adjacent to the full length of the proposed turnback siding.

Ref:	139797
Version:	1.1
Date:	June 2015

The site of proposed turnback siding is overgrown with shrubs and small trees which will require clearance prior to the installation of the new track and signalling infrastructure. Any environmental or ecological issues associated with this scrub clearance would require identification and management prior to the construction works.

Hallen Marsh Junction

Apart from the construction of a limited number of bases to support new signalling and M&E infrastructure the infrastructure alterations at Hallen Marsh Junction are essentially track and signalling in nature.

Two new crossovers are proposed and these can be formed using Network Rail's standard CEN 56E1 layouts on concrete bearers. The connection from the Bennets siding, at Holesmouth junction, is to be relocated and renewed some 150m to the north, Again this turnout will be formed using a standard CEN 56E1 layout on concrete bearers.

Four new trap points are required at the junction to protect passenger services from unauthorised freight movements. In order to avoid disproportionate damage to the track material in the event of a run off it is propose that these new trap points are formed on hardwood timber bearers.

The plain line forming the extension of the Bennets siding will comprise new jointed CEN56E1 rail on new/good serviceable concrete sleepers.

It is not possible to locate the new switch and crossing layouts on straight through alignments. Accordingly the three running lines will require design lining between 14m 40ch and 14m 62 ch to regularise the track geometry and curve/cant relationships.

The signalling alterations at the junction are very significant. Unless something like a seven day blockade of all lines were to be available to install and commission the new arrangements it is likely that the track layouts will be altered during a series of 30hr possessions and the signalling would then be commissioned during a bespoke 30 hr possession.

10.2 Access Strategy

The following access requirements are envisaged to permit construction and commissioning of the proposed works at each site.

North Filton

NOTE: Henbury and North Filton to use the same disruptive possessions as they are on the same line of route.

- 4x54hour disruptive possessions for construction of both platforms
- 1x29hour disruptive for footbridge installation

Ref:	139797
Version:	1.1
Date:	June 2015

Opportunity:

- Last 54hours could be utilised to install the footbridge subject to planning / efficiency therefore 1x29hour possession
- All platform work to be done as 'Adjacent Line Open (ALO)' under a Section C
- Assumption:
 - All track-work can be done Rules of the Route (ROR) as no significant alterations are required

Car park construction does not require a railway possession for work to be undertaken.

Henbury (Both Locations)

NOTE: Henbury and North Filton to use the same disruptive possessions as they are on the same line of route.

Spur Option (1A & 2A)

- 2x54hour disruptive possession to install Track work (1xDv Turnout & 1 x Cv Crossover)

Opportunity:

- Dv and Cv units could be installed under 1x54hour disruptive possession providing they can be planned / phased accordingly

Assumption:

- Platform construction under ALO fenced and new line installed in the same manner.

Loop Option (1B & 2B)

- 4x54hour disruptive possession for construction of both platforms
- 1x29hour disruptive possession for installing the footbridge

Opportunity:

- All platform construction under ALO Section C

Assumption:

- All track work undertaken under ROR Section C

Possessions for the loop option includes for all the work on the Henbury line including the track work and signalling alterations at Hallen Marsh should the loop option be chosen

Ref:	139797
Version:	1.1
Date:	June 2015

Yate

Track and Signalling

- 10x8hour mid-week night possessions of Down Charfield line
- 1x30hour disruptive possession to Install new turnout
- 1x8hour possession of Down Charfield line for Spate tamp
- 1x8hour possession of Down Charfield for Follow Up tamp
- Installation of plain line in turnback siding within fenced green zone

Network Rail has reviewed the possession requirements for the Stations on the Filton Bank, Ashley Down and Constable Road will use the same disruptive possessions, a summary is provided below:

Ashley Down

- 4x54hour disruptive possession for track works
- 1x29hour disruptive possession to install 2xcatch points Track work
- 4x54hour disruptive possession to construct both platforms
- 1x29hour disruptive possession to install footbridge

Opportunity:

- Use of High Output engineering train could cut track works possessions to 2x54hours, plus 1x29hours
- Footbridge could potentially be installed within the last 54hour possession

Assumption:

- All other works can be undertaken within Rules of the Route (ROR)

Constable Road

- 4x54hour disruptive for track-works (taking out and installing) plus 1 x 29hour disruptive for retarders (material and lay)
- 4x54hour disruptive possession to construct both platforms
- 1x29hour disruptive possession to install footbridge

Opportunity:

- Use of High Output engineering train could cut track works possessions to 2x54hours, plus 1x29hours
- Footbridge could potentially be installed within the last 54hour possession

Assumption:

- All other works can be undertaken within Rules of the Route (ROR)

Ref:	139797
Version:	1.1
Date:	June 2015

11. Cost Estimate

Summary Table

Scheme element	Cost Estimate (nearest £m 2015 prices)
North Filton Station	£7m
Henbury Station	£6m to £9m
Constable Road	£19m
Ashley Hill	£11m
Hallen Marsh Junction	£7m
Yate Turnback	£3m
<p>Exclusions:</p> <ul style="list-style-type: none"> • Local authority costs • Land acquisition • DNO or principle supply points • Disposal off site of contaminated excavated material including spent ballast with the exception of North Filton • Ground treatment or other geotechnical work for the Civil element of the works • Connecting the proposed car parking areas to the main highway network at North Filton and Henbury Stations (all options) • S&C lift costs do not include ground preparation for cranes etc. • Work to the level crossings in the Avonmouth area • Any costs associated with environmental and ecological consents or any work that may be required by such consents 	

Refer to Appendix D.

Ref:	139797
Version:	1.1
Date:	June 2015

12. Project Risks and Assumptions

A Qualitative Cost Risk Analysis (QCRA) workshop was held 8th December 2014 with the objective of identifying the projects risks for the MetroWest Phase 2 project.

Representatives of Network Rail, URS, South Gloucestershire Council, CH2M Hill and West of England Partnership were present. All participated in the deliberations.

The objectives of the meeting were to:

- identify significant risks to the achievement of the project objectives
- establish a project risk register in Active Risk Manager (ARM)
- conduct an assumption analysis and identify any constraints

The risks to the project were identified in a brainstormed session and risk owners were allocated. Each risk was then analysed to understand the probability of occurrence and impact of the risks on the project outcome.

Each risk probability and impact was scored qualitatively based on categories ranging from very high likelihood of occurrence / impact to very low likelihood of occurrence / impact. The qualitative assessments were uploaded into ARM and a score for each risk was automatically generated based on a probability/impact matrix.

The full QCRA can be found in Appendix E.

Ref:	139797
Version:	1.1
Date:	June 2015

13. High level business case appraisal against whole life costings

As set out in Section 4 Business Case, the economic appraisal is being undertaken jointly by NR and the Councils and is to be submitted to the WoE funding body in 2015.

Ref:	139797
Version:	1.1
Date:	June 2015

14. Project Schedule

Project Stage	Stage Description	Indicative Timescales
Stage 1	<ul style="list-style-type: none"> Option Development (GRIP 1-2) 	2014 - 2015
Stage 2	<ul style="list-style-type: none"> Scheme Case (GRIP 3) Detailed technical work and Business Case to support a major Planning application 	2015 - 2017
Stage 3	<ul style="list-style-type: none"> Planning Powers and Procurement (including GRIP 4-5) Planning consent awarded, procurement Completed, full business case completed Funding approval and contractual arrangements finalised 	2017 - 2019
Stage 4	<ul style="list-style-type: none"> Construction Completed (GRIP 6-8) Train Services operating from Spring 2021 	2020 - 2021

Ref:	139797
Version:	1.1
Date:	June 2015

15. Capacity/Route Runner Modelling

Please refer to Appendix F for the Network Rail Capacity Modelling Report.

Ref:	139797
Version:	1.1
Date:	June 2015

16. Interface with other projects

The design development of the MetroWest Phase 2 project will require integration with the following rail infrastructure projects:-

- The proposed quadrupling of the BSW route on the Filton Bank.
- The proposed provision of a fourth through platform at Bristol Parkway (IEP compliant length).
- The Great Western Electrification project.
- The enhanced renewal of Bristol East Junction.
- The Bristol Area Signalling Renewal & Enhancement Project
- The potential realignment of the Filton West Chord.
- Network Rail's asset renewal and heavy maintenance programme.
- MetroWest Phase 1

Ref:	139797
Version:	1.1
Date:	June 2015

17. Impact on existing customers, operators and maintenance practice

A Hazard Identification (HAZID) workshop was held on 21 January 2015. The HAZID forms part of the Common Safety Method and in particular the identification of hazards. The workshop considered the top level system hazards associated with the operations and maintenance of MetroWest Phases 1 & 2. The objective being to identify potential hazards and hazard causes associated with the operation and maintenance of the change in status and infrastructure imported by the project. The HAZID output will provide input to future design and development decisions.

Suitable competent representatives were present at the workshop.

For MetroWest Phase 2 the HAZID identified that the following are the top level hazards related to the system change:

- Slips, trips, falls (including stepping distance / access to trains)
- Trespass
- Poor rail adhesion (gradient of station/s)
- Passengers and workforce exposed to hazardous materials
- Noise from stationary train
- Workforce and member of the public safety
- Anti-social behaviour
- Exposure to electric shock voltages
- Overcrowding causing access problems to station and trains
- Vehicle incursions onto the railway
- Train driver distraction
- Flooding due to poor drainage

The hazards and hazard causes are recorded on the project Hazard log and the risk assessment process will be continued during the project life-cycle. This is to ensure that early and efficient opportunities are taken to control safety risk, so far as is reasonably practical, the application of the hierarchy of control and record decisions in construction, operation and maintenance.

Ref:	139797
Version:	1.1
Date:	June 2015

18. Consents Strategy

The consents required for this scheme will be complex and require detailed consideration by Network Rail (NWR) consents / legal team. Their view will be based on the definition of the scheme, final rail infrastructure ownership, as well as the operation and maintenance responsibilities.

Whilst Network Rail has Permitted Development Rights for changes to track and signalling on operational railways, these do not extend to new stations; where planning consent [or Transport and Works Act Order](#) would be required. For re-opening former stations, there might be 'prior approval' rights via old acts of parliament, but this would need researching on a site by site basis. Other factors may also include the requirement for changes to utilities and utility supplies to the new railway. Hence, the working assumption is that planning permission would be needed for the new stations.

On the Henbury Line stations, the adjacent CPNN developers have included stations in their outline planning applications, but their 'red line' does not extend beyond the railway boundary.

The new stations will require land out-with the ownership of the promoting authorities, Network Rail or CPNN developers. The promoting authorities will seek to secure such 3rd party land as required, primarily by negotiation, with recourse to Compulsory Purchase only if required.

The above considerations will indirectly influence the Environmental Impact Assessment (EIA), design development, land referencing and consultation requirements, as well as the overall programme to consent and beyond.

Ref:	139797
Version:	1.1
Date:	June 2015

19. Environmental Appraisal

Refer to Appendix G.

This specifically highlights environmental risks and information requirements. This appraisal also highlights a number of key issues that have programme and design implications including ecology, noise, traffic, drainage, contamination and so on. It recognises the need to identify the design, construction and consent related issues/information requirements that will be associated with the next phase (GRIP 3) to ensure the EIA can be completed and the consents requirements and programme met.

Ref:	139797
Version:	1.1
Date:	June 2015

20. Common Safety Method for Risk Evaluation Assessment (CSM)

CSM came into force on 1st July 2012 to facilitate mutual recognition between EU Member states of risk evaluation and assessment processes to comply with Railway Interoperability Regulations (RIR) legislation. A submission for assessment under the Railway and Other Guided Transport Systems (Safety) Regulations 2006 (ROGs) for MetroWest Phase 2 is to be made prior to commencement of GRIP 3.

Ref:	139797
Version:	1.1
Date:	June 2015

21. Client Contracting Strategy

The contracting strategy is to be fully considered in GRIP 3, but current thinking is presented below.

Overview of Output Specification

Stage of scheme development	Work-stream	Output
Preparation	GRIP 3 (& 4) combined procurement, reported upon completion of each stage – direct procurement with Network Rail	Completion of GRIP 3 (& 4) deliverables feeding into completion of Outline Business Case
	Modelling & Appraisal – BCC Transport Term Consultant	Completion deliverables for WebTAG compliant Outline Business Case and Full Business Case
	Environmental assessment – BCC Transport Term Consultant	Completion of evidence base for any environmental assessments required
	Project Management Support – BCC Transport Term Consultant, on-going	Provision of sufficient project management capacity, reflecting the dimensions of the scheme
	Legal – in-house (supported by extant framework) and/or Network Rail	Provision of legal support to acquire statutory consents (e.g. planning)
	Communications – WoE communications Team and Project Management Team led, on-going	Provision of support for Stakeholder management
	Land & Property – in-house	Provision of support for land negotiation, referencing and assembly
	Rail Operations – Parallel dialogue between incumbent operator (FGW) and DfT Rail – Project Management Team led	All operational requirements
	Commercial – Project Management Team led, on-going	Approach for procurement of construction and operation of scheme, is set out below
Construction	Station accesses, parking, interchanges - in-house (supported by extant framework) and/or Network Rail	Non-trackside infrastructure design.
	Rail Construction <ul style="list-style-type: none"> New stations 	New stations (track-side facilities), track and signalling to meet compliance requirements for acceptance into

Ref:	139797
Version:	1.1
Date:	June 2015

Overview of Output Specification

Stage of scheme development	Work-stream	Output
	<ul style="list-style-type: none"> Track & signalling 	<p>national rail network (i.e. GRIP 7 & 8 handover and project close, is contractors liability).</p> <p>Works completed in accordance with programme.</p>
	<p>Non-trackside infrastructure</p> <ul style="list-style-type: none"> New station accesses and associated facilities 	<p>New station accesses and associated facilities to meet compliance requirements for acceptance into national rail network (i.e. GRIP 7 & 8 handover and project close, is contractors liability).</p>
Operations	Train Operator and Train Service	Train operator is procured and train service commences in accordance with programme

Preparation

The table above sets out the main preparation work-streams; other than GRIP 3 (&4), they would be undertaken using the council's in-house resources and/or through extant framework contracts. It is proposed to appoint Network Rail to undertake GRIP 3 and 4; Network Rail would procure contractors from its frameworks. Whilst only GRIP 3 is required for input to the Outline Business Case, procurement of a combined GRIP 3 and 4 contract could yield efficiencies and save time compared with procuring them separately. This will be considered further and approval for the preferred option sought from local authority Members and the Board.

Construction

The table sets out two major work streams; rail construction (track, signalling, stations) and non-trackside construction (station accesses and associated facilities out-with Network Rail ownership).

It is proposed that rail construction be one or more GRIP 5-8 Design and Build contracts through a competitive procurement led by Network Rail; this would be alongside a separate 'Delivery Agreement' between the councils and Network Rail.

There are options for the non-trackside infrastructure construction: bundling the works into the aforementioned Network Rail trackside construction contracts; or separate contracts using the council's in-house resources and/or framework contractors. Contracts for station construction could be split station by station, by groups of stations or as a single parcel of work.

Ref:	139797
Version:	1.1
Date:	June 2015

Operations

There are three options for the procurement of the train services:

- a) via DfT Rail, TOC and base franchise specification;
- b) A 'priced option'; and
- c) An open market approach subject to ORR agreement

The currently preferred option is (a), 'procurement via DfT Rail'; because the start of Phase 2 services would be in 2021 , which would be in the early years of the next Great Western franchise and the specification for Phase 2 could be fed into the tender specification.

The MetroWest Phase 2 project team will engage with DfT Rail and the TOC on the above options, as the project progresses through GRIP 3 and the Outline Business Case.

Ref:	139797
Version:	1.1
Date:	June 2015

22. Concept Design Deliverables

There are a number of drawings contained in Appendices J. The drawings are plotted on OS (Ordnance Survey) maps to give a dimensional picture of the route. These drawings also give additional detail such as access points, crossings, Station locations etc. The index of drawings is as follows:

Deliverable Number	Office	Discipline	Type	Number	Description
47072043	SW	PW	DRG	7004	Hallen Marsh Jcn Potential Enhancement to facilitate Passenger Services to Henbury & Bristol Temple Meads
47072043	SW	PW	DRG	7001	Henbury Station Option 1A (Spur) and Option 1B (Loop) Eastern Location
47072043	SW	PW	DRG	7002	Henbury Station Option 1A (Spur) and Option 1B (Loop) Western Location
47072043	SW	PW	DRG	7003	North Filton Station
47072043	SW	CV	DRG	0001	North Filton Station Plan
47072043	SW	CV	DRG	0002	Henbury Station Option 1A (Spur) and Option 1B (Loop) Eastern Location
47072043	SW	CV	DRG	0003	Henbury Station option 1B (Loop) Eastern Location Plan
47072043	SW	CV	DRG	0004	Henbury Station option 2A (Spur) Western Location Plan
47072043	SW	CV	DRG	0005	Henbury Station Option 2B (Loop) Western Location Plan
47072043	SW	PW	DRG	7005	Yate Turnback Siding
SDG/SSK/139797	BM	SDG	DRG	GS2/5	Yate Turnback Option Scheme Sketch
SDG/SSK/139797	BM	SDG	DRG	GS2/4	Spur Line Option Scheme Sketch
SDG/SSK/139797	BM	SDG	DRG	GS2/1	Circular Route Scheme Sketch 1 of 3
SDG/SSK/139797	BM	SG	DRG	GS2/2	Circular Route Scheme Sketch 2 of 3
SDG/SSK/139797	BM	SG	DRG	GS2/3	Hallen Marsh Junction 2.2

Ref:	139797
Version:	1.1
Date:	June 2015

23. Conclusion and Recommendations

The work undertaken by this study provides technical information to support passenger services as proposed under MetroWest Phase 2 to operate to Henbury on the existing freight only Avonmouth & Filton Railway (AFR). The study looked at the frequency and service patterns of passenger rail services to operate via a loop or a spur. The timetable modelling work undertaken has paid due cognisance to maintaining the existing freight path agreements.

The study builds on the MetroWest Phase 1 two services option 5b & 6b. Capacity exists to deliver the Phase 2 service specification for a loop or a spur option should the proposed infrastructure interventions be delivered. However, the timetable modelling does highlight that linking the loop service to the Phase 1 Portishead services at Bristol Temple Meads to then connect to Severn Beach Line services and create the proposed 'loop service' imports unacceptable performance risk to the industry. An alternative scenario for a standalone loop service was explored however this option would result in units idling at Bristol Temple Meads (or an alternative stabling facility would need to be created) for an extended period of time utilising valuable platform capacity and impacting on train performance in the station area. The extended dwell time would impact and spread performance delay to the wider Bristol and Western Route area.

For a loop service to operate:

- the platforms for Henbury Station would be adjacent to the Up and Down lines whether the Station is located at the Eastern site (option 1B - new) or the Western site (option 2B - historic)
- Henbury Station would be on a gradient requiring a derogation to deviate from Railway Group Standards
- substantial trackwork and significant signalling alterations are required to Hallen Marsh Junction to enable both passenger and freight services to operate
- reduced standage on the port arrival and departure lines
- there would be an adverse impact on vehicular access to/from Avonmouth Dock at St. Andrews Level Crossing, which cannot be mitigated by track and signalling enhancements

In contrast for a spur service operation:

- can operate in isolation with a far smaller performance risk
- train services would terminate at Henbury off the running lines at either the Eastern (option 1A – new) or Western (option 1B – historic) Station location
- Henbury Station would be constructed on a level gradient with a straight horizontal alignment. No derogation to Standard required.
- two less train units required to run the timetable reducing operating costs

Ref:	139797
Version:	1.1
Date:	June 2015

- freight services can be regulated into and out of Avonmouth dock between Henbury and Hallen Marsh
- there would be no adverse impact on vehicular access to/from Avonmouth Dock at St. Andrews Level Crossing

Infrastructure and disruptive service costs are significantly higher and design and build more complex for the loop service option. With a spur operating scenario passive provision can be made between the existing running line and the bay platform line at Henbury Station to enable a loop service operation to be provided should this be required at a later date.

In summary for passenger services to operate to Henbury Network Rail would recommend the spur service option is taken forward to GRIP 3 as this option imports less risk to train performance and less complex infrastructure intervention. The station for the spur option would be constructed off the main lines on a level gradient with a straight horizontal alignment; no derogation to the Railway Group Standard would be required.

This study undertook a review of the CH2M Hill Report on the location of additional stations on Filton Bank at Ashley Down and Constable Road. Ashley Down is an historic station location close to residential housing and whilst there is no car park the site has the potential to attract local residents. Constable Road is a new station location; the site is currently an undeveloped area of a small industrial estate off Romney Avenue. The proposed station is remote from residential areas which could deter the local community from using this new rail facility. Both these sites are on a gradient which will require derogations to be obtained from Railway Group Standards to construct and operate a station(s).

Ashley Down and Constable Road are within close proximity of each other and relatively close to Filton Abbey Wood Station. The WoEP will need to determine whether the area can support a new station or two within half a mile of each other. In addition further work will need to be undertaken to assess the wider impacts of train performance and network capacity of having a new station(s) on the Filton Bank.

It is recommended that the Bristol Area Signalling Renewal project and other CP5 track renewal or enhancement projects consider the requirements of this project and opportunities are identified to design / deliver infrastructure through a holistic approach. A key issue is the positioning of stanchions and isolation points for the electrification of the Filton Bank. It is important that dialogue with the GW electrification and the Filton 4-track project is maintained to minimise impact to the future design and delivery of the new station(s) proposed at Ashley Down and/or Constable Road.

For MetroWest services to Yate it will be necessary for additional infrastructure to be built off the main lines to reduce the risk to performance by providing a turnback siding. However, if MetroWest services are to extend to Gloucester the new turnback facility would not be required. The WoEP will need to establish the viability of a service extension to Gloucester and whether the Yate turnback is required as an interim measure or not at all.

Ref:	139797
Version:	1.1
Date:	June 2015

Existing structures and earthworks will need to be assessed for structural capacity (where applicable) and their condition evaluated for the proposed trains. Interoperability and safe access for examination and maintenance activities should also be determined. Early discussions with the Civils and Geo-technic Network Rail Asset Managers is recommended to determine requirements and for acceptance of any redundant assets back into operation, maintenance regime requirement, acceptance for increased loadings over operational assets.

The Civils Network Rail Asset Manager will also need to agree any proposed significant track renewals over, under or adjacent to any structures, as well as any track raising or lowering over and under any structures respectively. The Risks associated with these factors include: overloading of structures, increasing lateral pressure on retaining/ballast walls/arch faces and removal of passive resistance to sliding /undermining the foundations of retaining/abutment walls. A key Project risk is that significant strengthening or repair works above the initial scoped works may be required. These risks are to be evaluated and identified by the Project in the Hazard Log.

In conclusion the report demonstrates that the proposed services together with the identified infrastructure changes are feasible and recommends that the project progresses to the next GRIP stage. However, the WoEP will need to evaluate the economic and social value of the various options and together with all Stakeholders determine which options are to be taken forward to GRIP 3.

Ref:	139797
Version:	1.1
Date:	June 2015

Formal Acceptance of Selected Option by Client, Funders and Stakeholders

Client:			
Comments:			
Acceptance:		Date:	